

May could be marked as a month of forthcoming anniversaries. D-Day, the Allied invasion to France, 70th anniversary will come in June and centenary anniversary of the World War I or the Great War will be celebrated in summer. We decided to commemorate both of these anniversaries. The first one by two kits featuring invasion stripes in 1/72 and 1/48 scales. For the Great War centenary in the summer we will release a 1/32 scale kit of a Bristol M.1C fighter. And that's not all. Except of these anniversary kits you'll be bale to order other two kits. At the end of May or in the beginning of June the distribution of the long awaited 1/72 scale AH-1G Cobra kit will start, so far in two boxes. Nevertheless, this kit deserves special newsletter in which we will inform about its release. Now back to the forthcoming kits...

### SH48128 Supermarine Seafire Mk.III „D-Day Fleet Eyes“ 1/48

Bar Code: 8594071084363

Seafire Mk.III was the best naval fighter of British design to enter the WW 2. Even though the fragile undercarriage was a slight handicap of this aircraft in the air it was formidable opponent. German, Italian and even at the end of the War the Japanese pilots could see it for themselves. Seafires were deployed not only as fighters. Seafires of the No.3 Naval Fighter Wing were based at the South England airfields and flew sorties to the Normandy beaches.



The sorties were flown in pairs and directed the invasion fleet's battleship fire. It was a dangerous work since the low flying machines were endangered by both AA fire and enemy fighters.

The kit offers two machines from No.3 Naval Fighter Wing with the invasion stripes applied. The first one is particularly interesting since when its tail planes were replaced they were painted by base grey-green colour. Two pilots were successful in aerial combat with enemy fighters. In the contrary, the second machine illustrate how dangerous was the battleship fire control mission. This machine was shot up and forced to emergency land in the enemy territory on the second

day. The pilot successfully crossed the frontline and returned to its unit.

The kit contains five sprues with grey plastic parts, injected canopy, photo-etched parts and self adhesive masks.

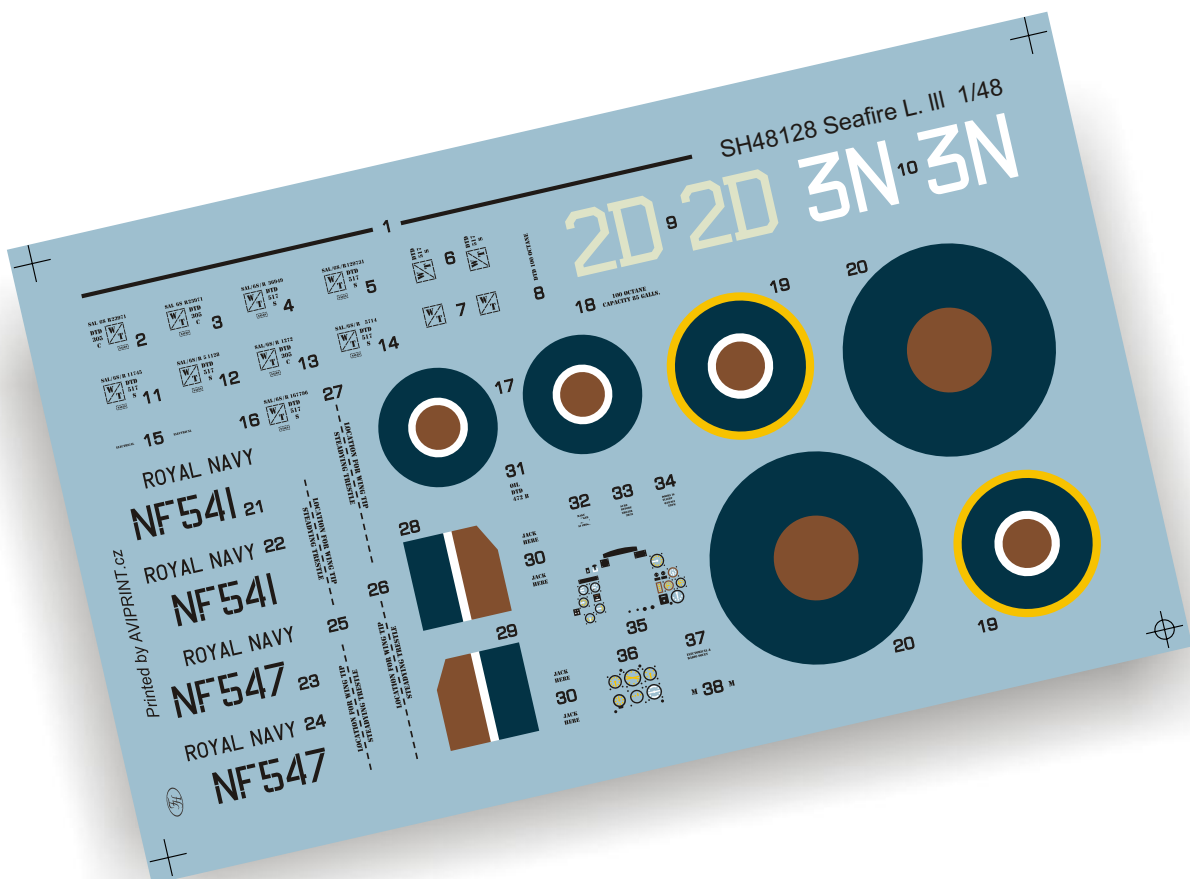
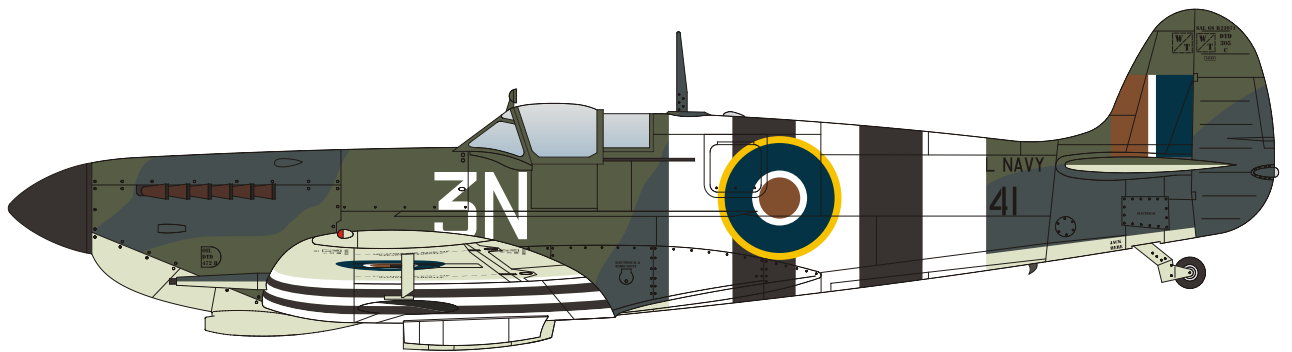
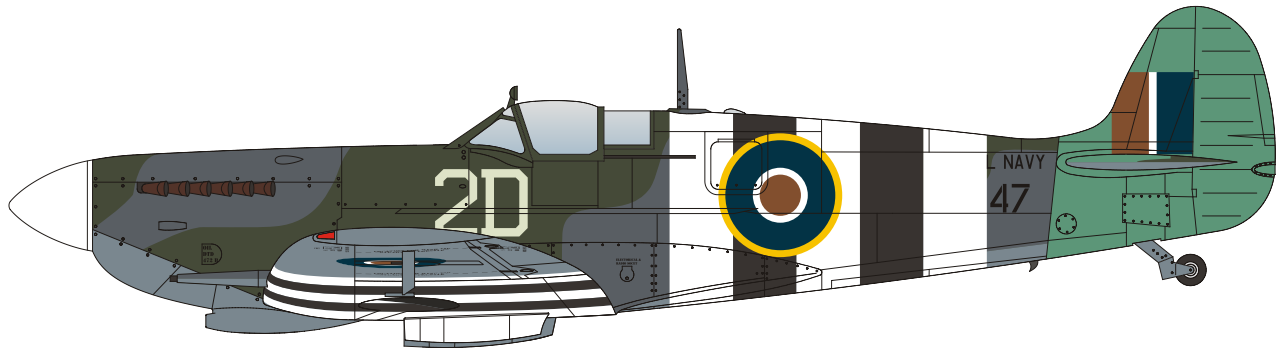

The light bombers designated A-20 Havoc in US and Boston in British air forces formed a significant part of the Tactical Bomber Air Force deployed prior and during the invasion. RAF used Bostons from No.88 Squadron flew sorties to deploy the smokescreen. These machines had the stripes similar to the invasion ones applied already in 1943 during the fictive invasion Operation Starkey. We decided to



add one Boston in the Starkey Operation camouflage featuring the smoke generators. But the kit offers true invasion machines. Highly successful RH-B machine from RAF No.88 Squadron decorated with beer keg painting and mission markings and two machines from No.342 "Lorraine" Squadron (GB 1/20 Lorraine) of the Free French Air Force. One of them carried British roundels the other had the French already applied.

The kit contains five sprues with grey plastic parts, injected clear parts and resin cast smoke generators' pipes.

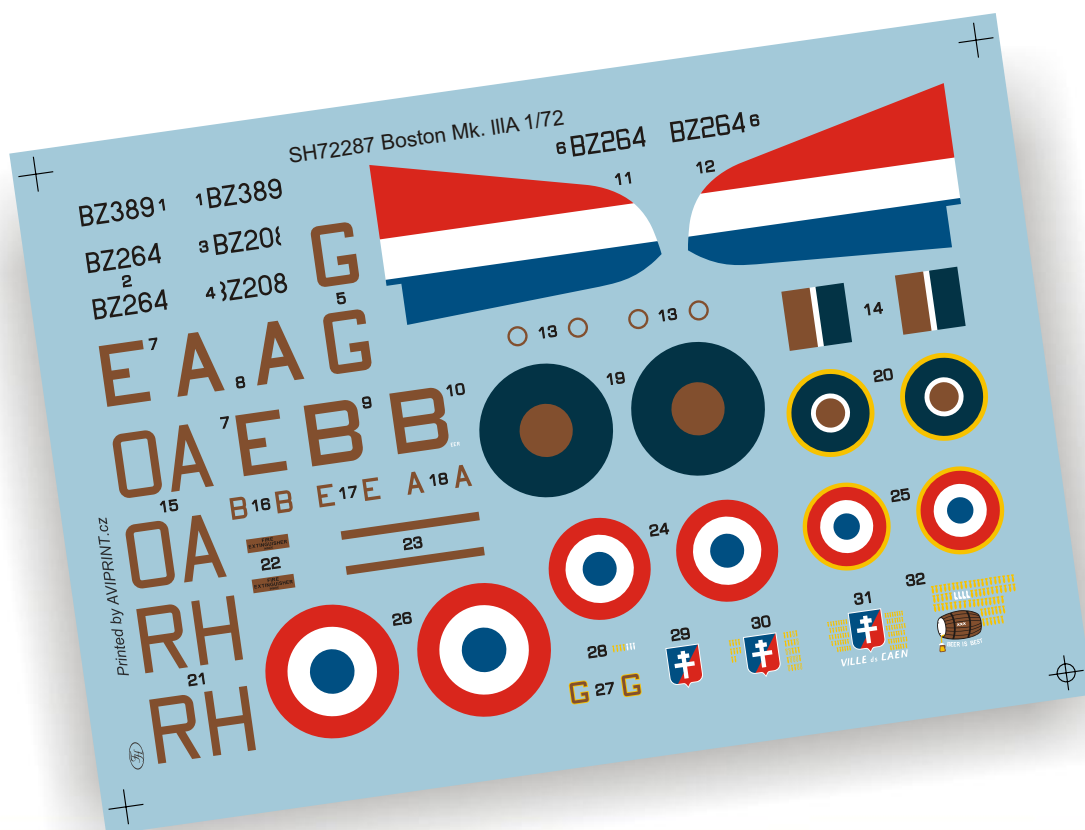

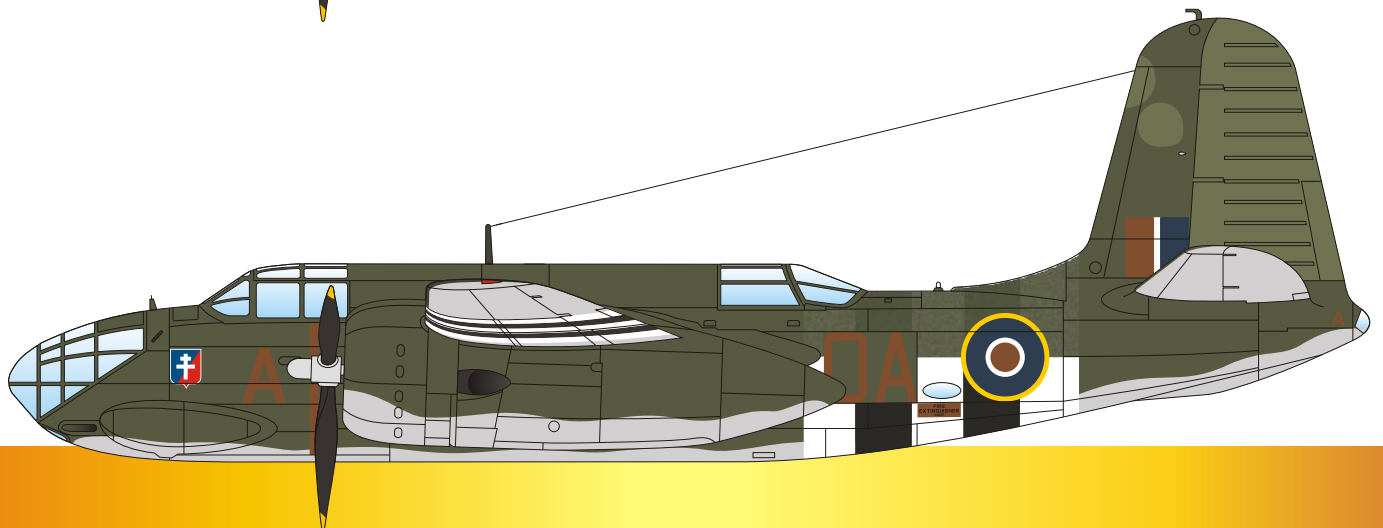
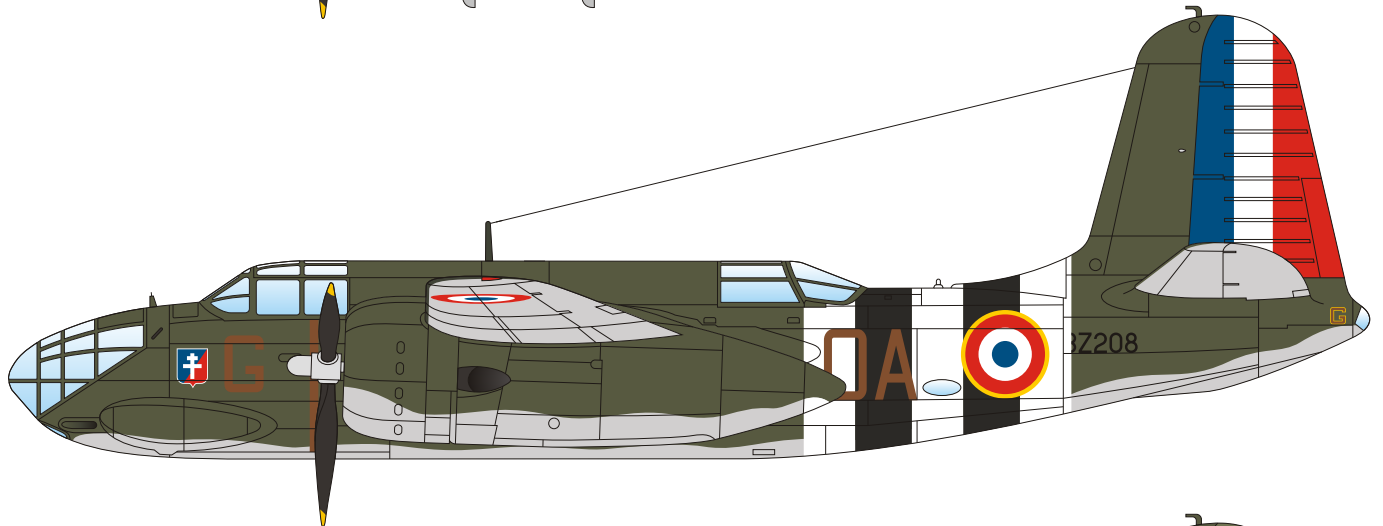
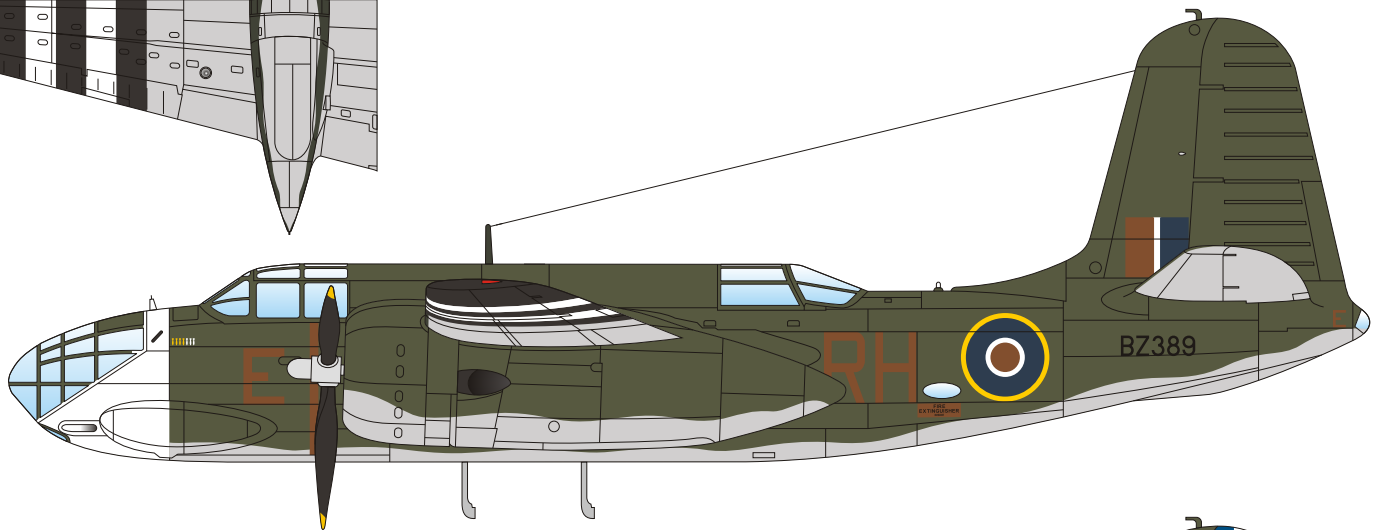
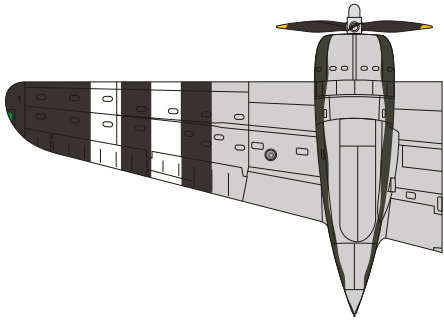
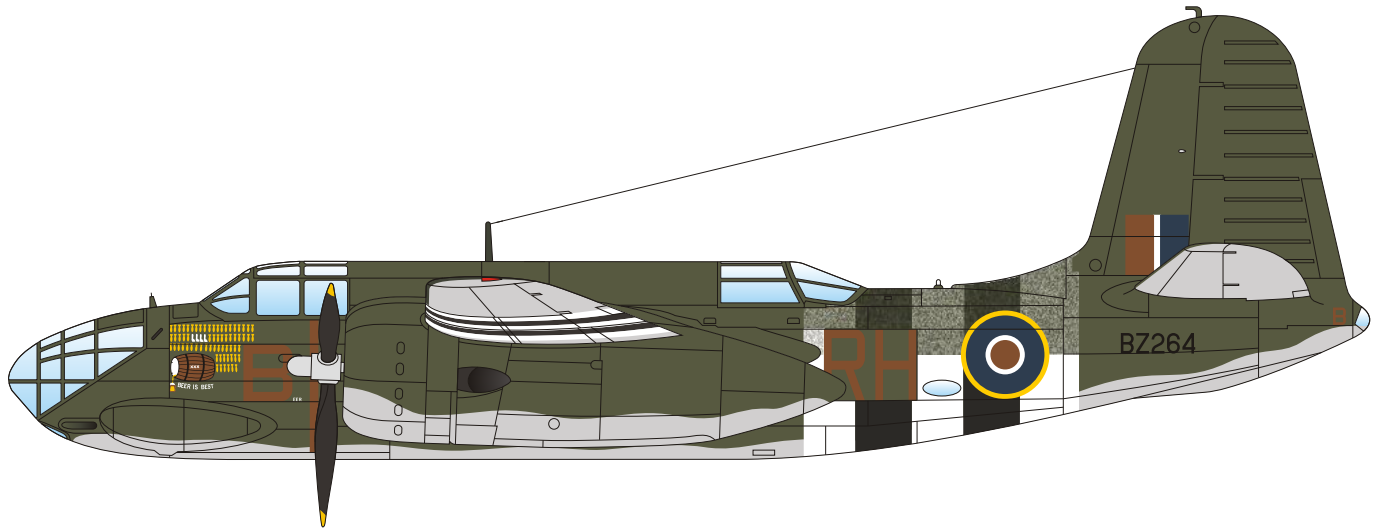



US T-33A machines became the world's widely used jet trainer aircraft. The list of its users is impressively long. The service career of this aircraft cannot be included on one decal sheet of one kit. We had to choose the most interesting, particularly from the machines that served in Europe. We chose US, German, French and Dutch machines. US 57. FIS. machine was deployed to Iceland and during its service its camouflage changed from multi coloured one with mouth painting



on its nose to overall grey with red markings and black and white checkers. German machine from JG71 sports Hartman's tulip painting on the nose. The French machine is of note for its fancy coloured fin that featured marking of several units the machine subsequently served with. Even the relatively sober camouflaged Dutch machine was fancy coloured with colour markings, as the trainer machine should be.

Huge box contains six sprues with grey plastic parts, injected clear parts (part of them is injected from metal mould), detailed resin parts, coloured photo-etched fret and three A5 format decal sheets.

Similarly to other states, to enforce its air force prior the World War 2 Netherlands ordered aircraft in the USA. Among other ordered aircraft, order was placed for Douglas DB-8A-3N. It was Northrop Co. original design that was purchased by Douglas. The successful Northrop/ Douglas machines, in various versions differing in engines and fixed or retractable landing gears (and thus the designation), were purchased not only by USAAF but also by couple of European, South American and Asian countries. According to the specifications the Dutch machines were powered by R-1820 engines. Although the original purpose was bombing missions, the Dutch machines were deployed as bomber interceptors; therefore DB-8A-3N victory count lists several German bombers. Several machines survived the occupation of Netherlands and were seized by Luftwaffe that used them for tests and training.

This limited edition kit offers marking for one of the German trainer aircraft. This machine features complete German insignias and sports Luftwaffe Trainer School emblem below the canopy.

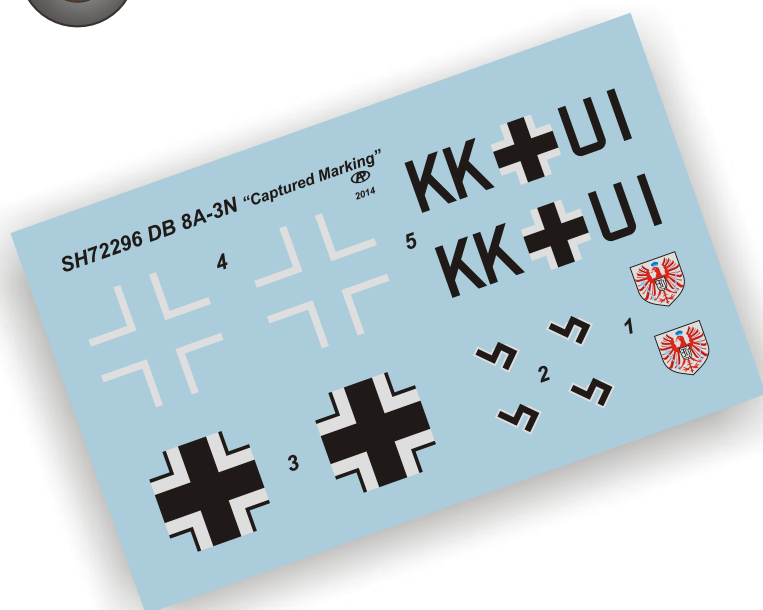
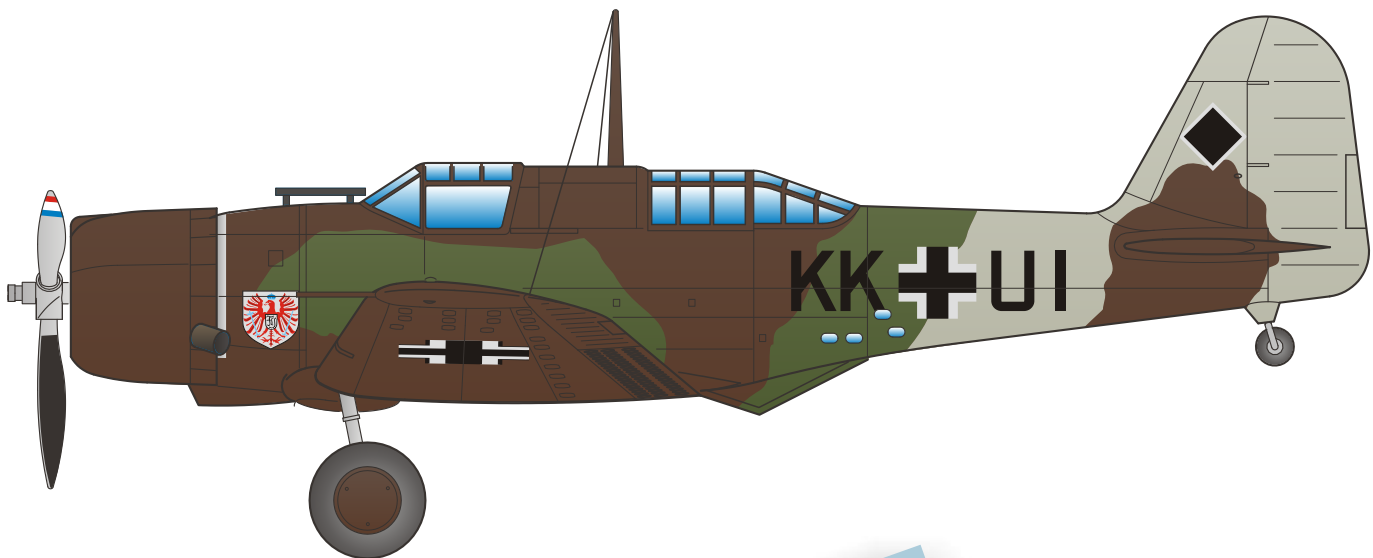

MPM Production continues to prepare its kits completely in 3D design and inject them into metal moulds. Some of the kits are already on sale **A4/V2** rockets, **SS-100 Gigant** tractor and **Meillerwagen** rocket trailer. We present the test shots of the final kits of **AH-1G Cobra**, **AH-1Q/S Cobra** and day fighter versions of **DH 100 Vampire**. Both Vampire and Cobras in quality exceed every kit of these subjects that was in 1/72 scale ever produced. Now it's time to reveal our next project. We had already started to prepare moulds for trainer aircraft **Fouga Magister** and its versions. We will, subsequently release **CM 170 Magister** in both trainer and combat version (including **IDF Tzukit**), aerobatics version with faired over rear canopy and even **CM 175 Zéphyr** naval version. The differences from the standard Magisters comprise lengthened fuselage, different canopy, arrestor hook and strengthened undercarriage.

# Fouga CM 170 Magister 1/72

- HIGHLY DETAILED CM170 / 175 MAGISTER / ZÉPHYR MODELS IN SEVERAL VERSIONS TO BE LAUNCHED IN THE NEAR FUTURE
- COMPLETELY 3D DESIGNED, INJECTED INTO METAL MOULDS
- FINE DETAILS, SHAPE AND DIMENSIONAL ACCURACY

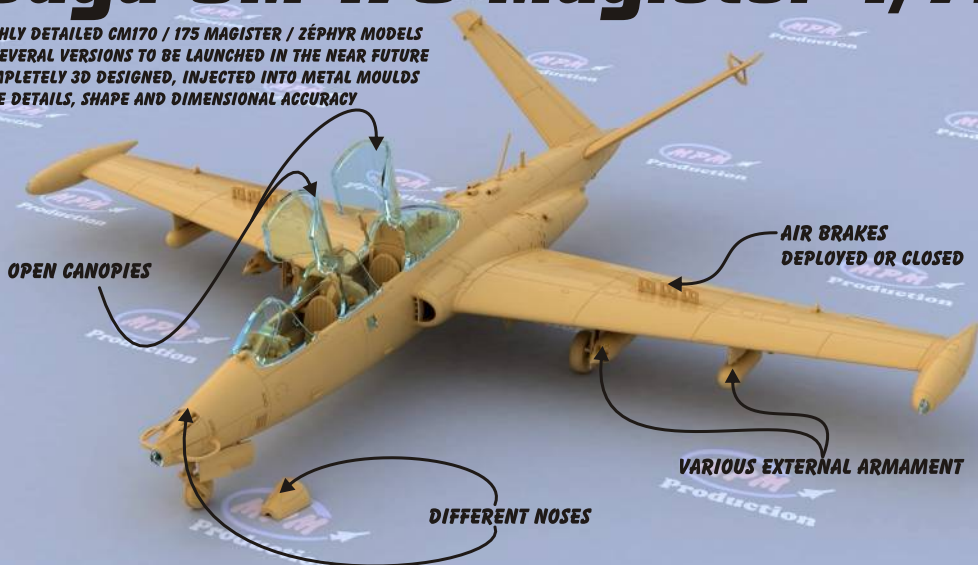

**A GOOD MODEL IS WORTH THE WAIT!**



# Fouga CM 175 Zéphyr 1/72

- HIGHLY DETAILED CM170 / 175 MAGISTER / ZÉPHYR MODELS IN SEVERAL VERSIONS TO BE LAUNCHED IN THE NEAR FUTURE
- COMPLETELY 3D DESIGNED, INJECTED INTO METAL MOULDS
- FINE DETAILS, SHAPE AND DIMENSIONAL ACCURACY



**A GOOD MODEL IS WORTH THE WAIT!**





# Mirage F.1

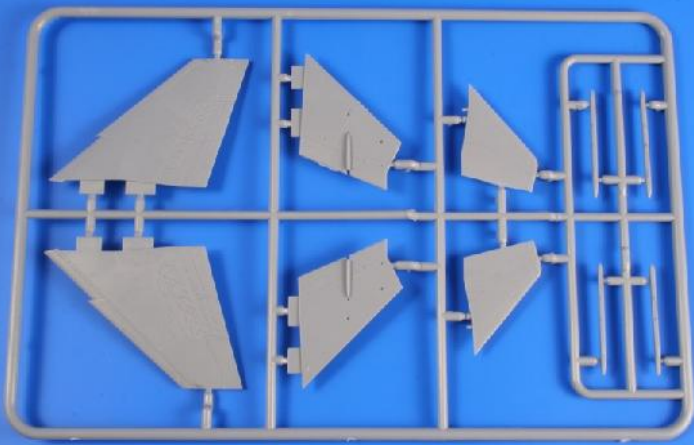
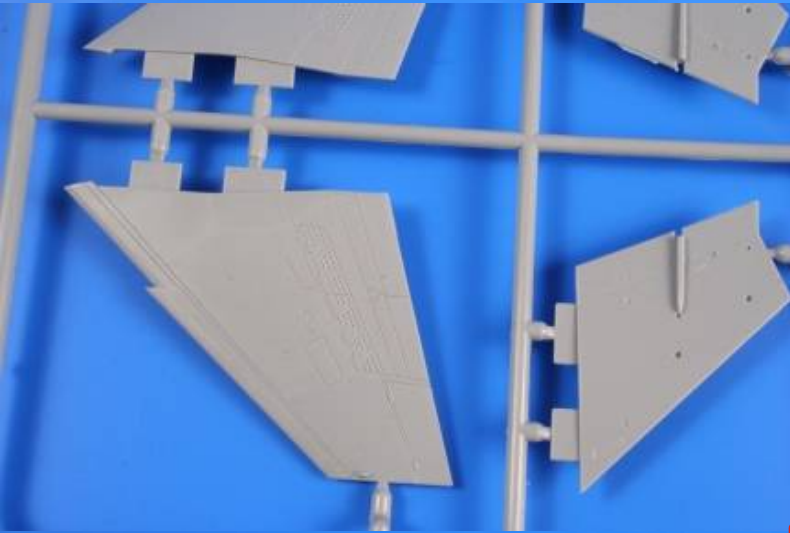
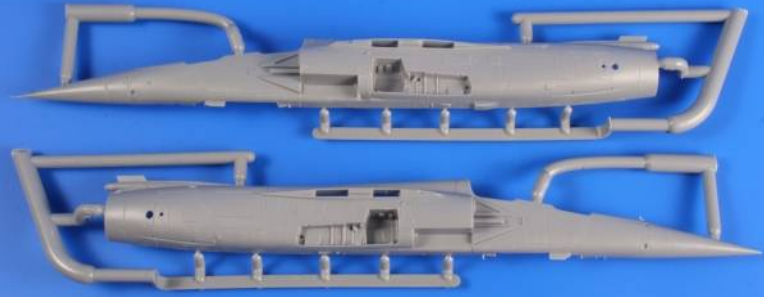
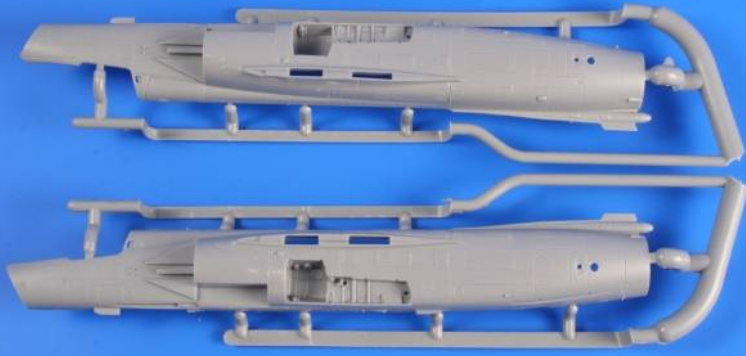

# Fouga / Zéphyr

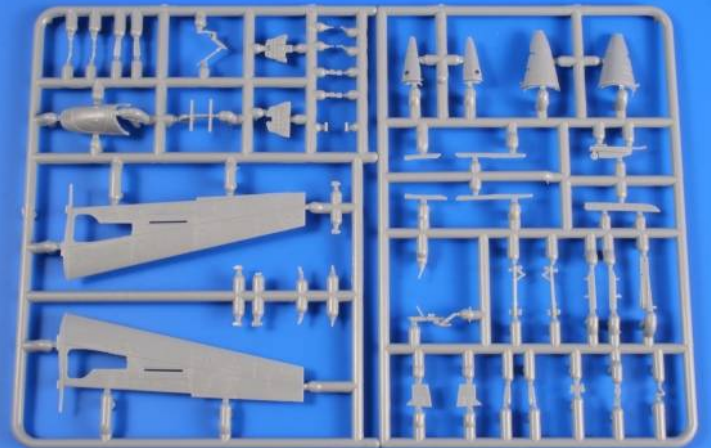
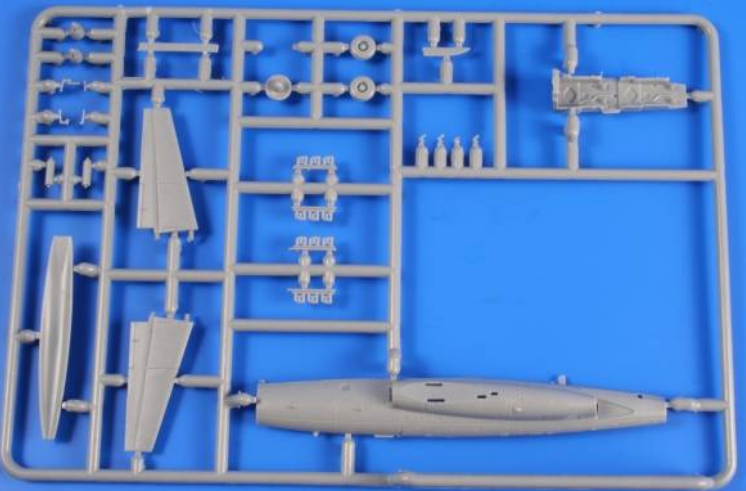



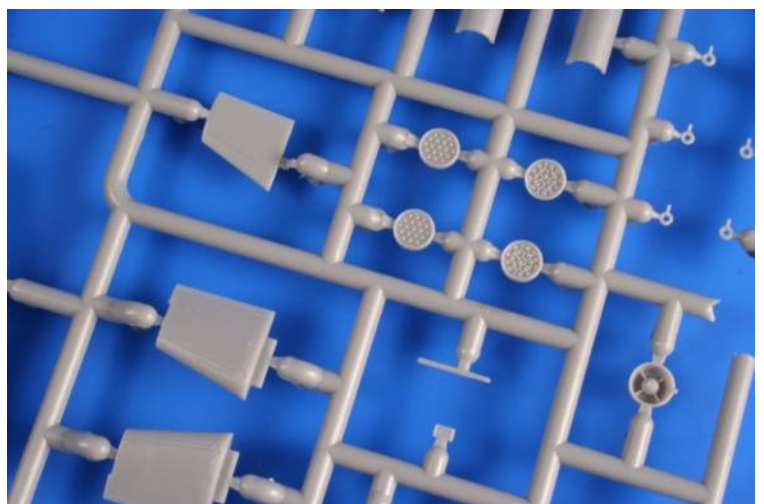
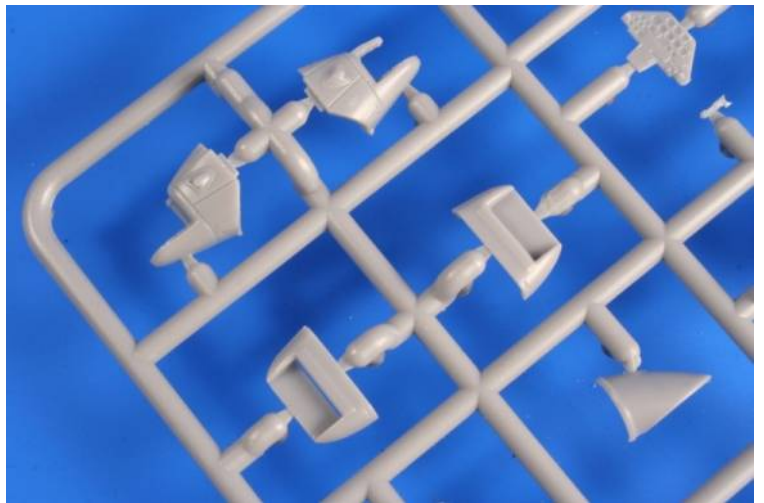
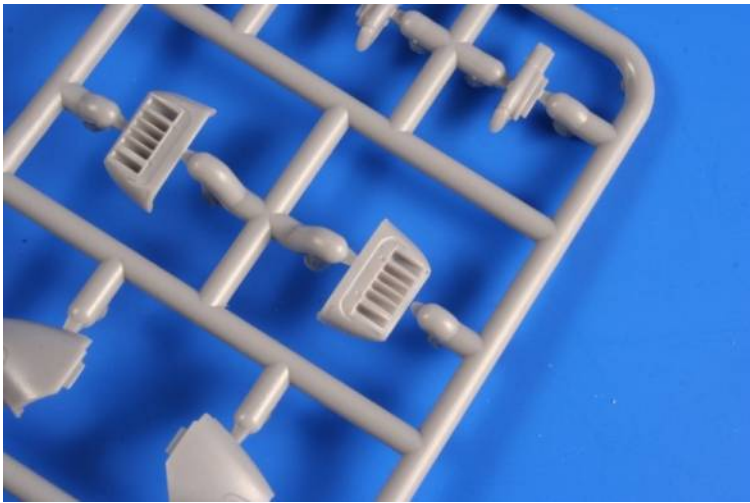
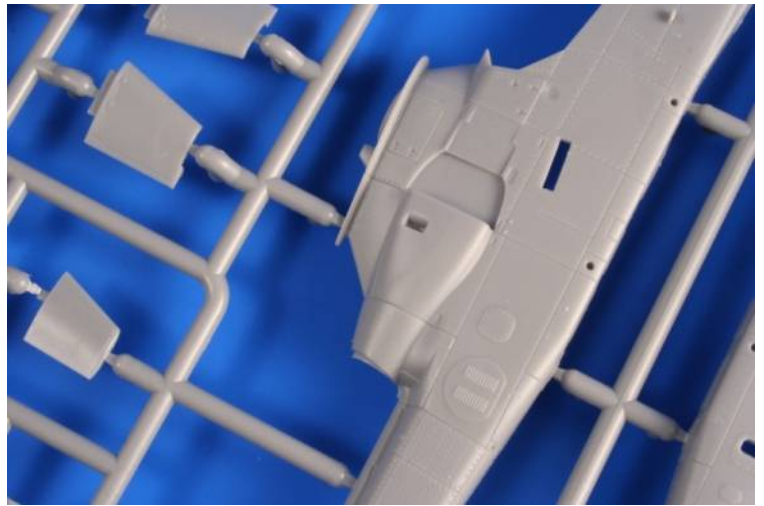
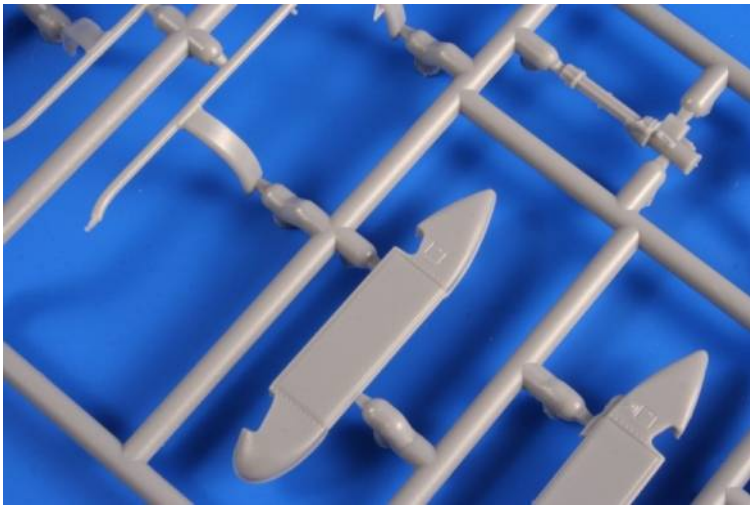
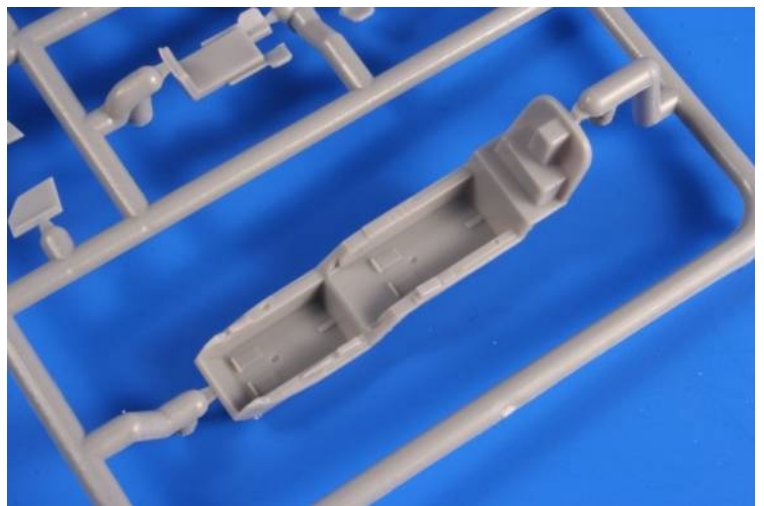

**AH-1G Cobra & AH-1 Q/S Cobra testshots**



# Forthcoming new releases:

SH48135

AF-2S Guardian "Submarine Killer" 1/48



SH72274

AH-1G "Spanish & IDF Service" 1/72



SH48158

AF-2W Guardian "Submarine Hunter" 1/48



SH72290

IAR-37 "Rumanian Light Bomber" 1/72



SH72293

IAR-38 "Rumanian Reconnaissance Plane" 1/72



SH32057

Bristol M.1C "Wartime Colours" 1/32



SH48123

F-86K Sabre Dog "NATO All Weather Fighter" 1/48



SH48126

F-86K Sabre Dog "Armée de l'Air & BundesLuftwaffe" 1/48





# AH-1G Cobra 1/72



SH72076

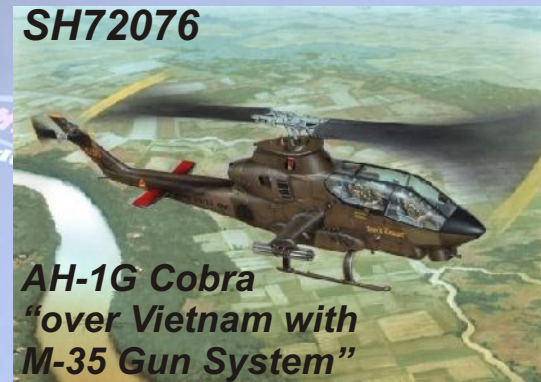

AH-1G Cobra  
"over Vietnam with  
M-35 Gun System"

# AH-1Q/S Cobra



SH72278



AH-1G Cobra  
"Over The USA and Europe"

SH72280



AH-1G Cobra "Marines" 1/72



**Tempest MK.V/VI**



**Tempest MK.II**





# RESIN KITS and SETS 05/2014

MPM Production Ltd., Mezilesí 718, 193 00, Praha 9, Czech Republic  
tel.: +420 281 923 909 fax: +420 281 923 910 e-mail: cmk@mpm.cz  
official website and e-shop: www.cmkkits.com

ITEM  
7292

## Vampire T.11 - Control surfaces set for Airfix kit

Scale  
1/72

The level of detail of the highly popular Airfix Vampire T.11 model can be improved with the use of this set of cast ailerons, rudders and tailplane with separate elevator. **GB / Post WWII**

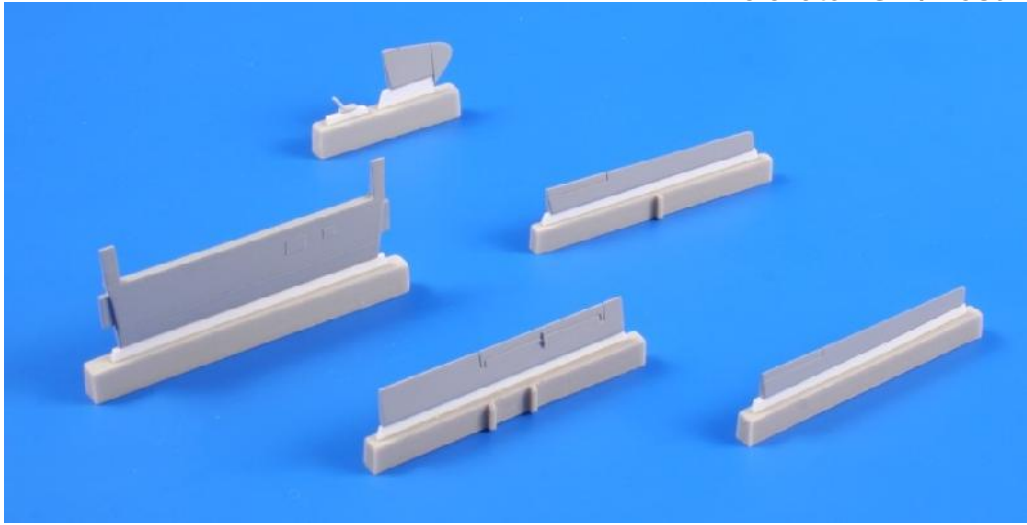

Bar Code: 8595593121055

ITEM  
7293

## Vampire T.11 - Interior set for Airfix kit

Scale  
1/72

Your new Vampire T.11 model by Airfix can be enhanced by this detailed cast set that includes new cockpit floor, side-walls, Martin-Baker Mk.3B seats, instrument panel and other details and also colour photo-etched parts. **GB / Post WWII**



Bar Code: 8595593121062

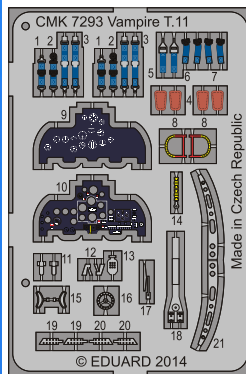

ITEM  
7294

Scale  
1/72

### Napier Sabre series Mk.II - WW II British aircraft engine

Highly detailed cast model of one of the most powerful and also most-complicated piston engines of the Second World War, the H-24-cylinder Sabre series Mk.II of Napier company. Production engines were installed to the Hawker Typhoon and Tempest fighters. Almost identical Sabre Mk.III powered the Blackburn Firebrand Mk.I attack planes. Sabre engines were also installed in the Hawker Fury and Martin-Baker MB-3 prototypes and test-flown in the Fo 108 and Warwick machines.

**GB / WWII and post WWII**

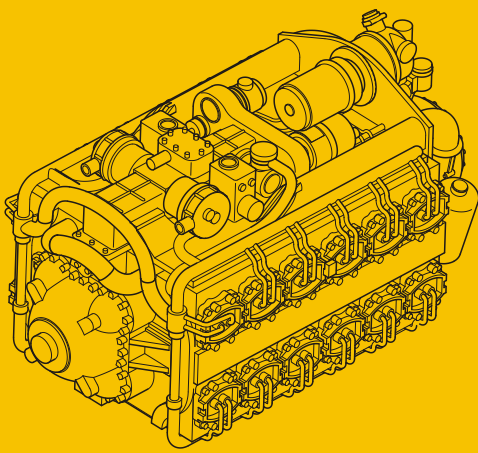

Bar Code: 8595593121079

ITEM  
7295

Scale  
1/72

### Typhoon Mk.I - Engine set for Airfix kit

The set contains complete Napier Sabre Mk.II engine and its installation, engine bulkhead, bearers, oil tank, exhausts and covers. This British WW2 fighter made itself famous in a interceptor role against German fighter-bombers and also in ground attack sorties in the occupied France.

**GB / WWII**

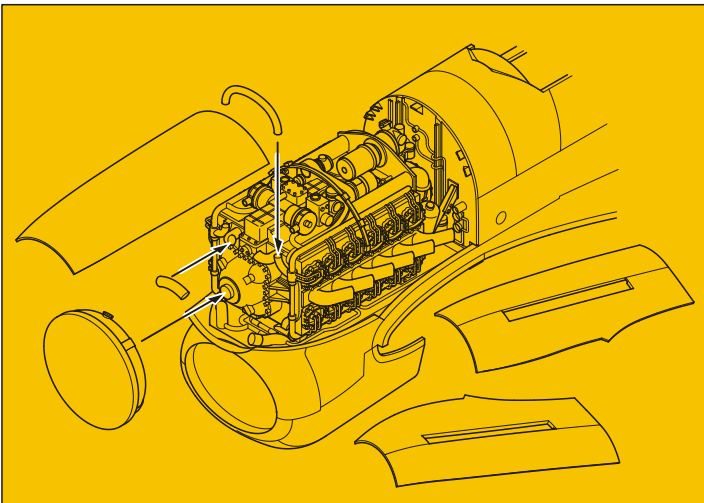

Bar Code: 8595593121086

MV 114 Fuel Storage Tank Container PL2

8WPU 012 852	8WPU 010 840	8WPU 000 837	10	4
13	12	11		
8WPU 012 852	8WPU 010 840	8WPU 000 837	10	4
228	226	220		
8WPU 012 852	8WPU 010 840	8WPU 000 837	10	4
15	15	14		
8WPU 012 852	8WPU 010 840	8WPU 000 837	10	4
228	226	220		



**ITEM**  
**MV 114**

**Fuel Storage Tank Container - full resin kit**

**Scale**  
**1/72**

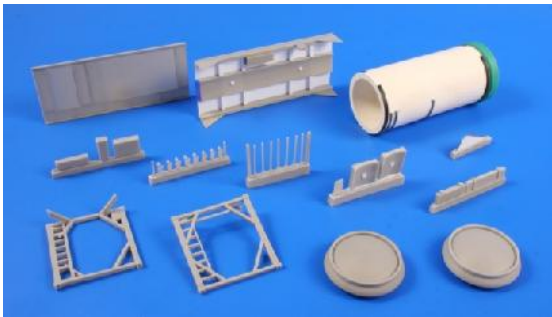

Full-resin model of fuel tank in its transport container. These containers are widely used in military and humanitarian missions in Europe or Afghanistan. Both front-ends, manhole covers, top frame with walk-sheets, side frames, bottom understructure, railing, fuel nozzle and control boxes are to be attached to the tank. The set contains decal sheet.

**Germany / Modern**

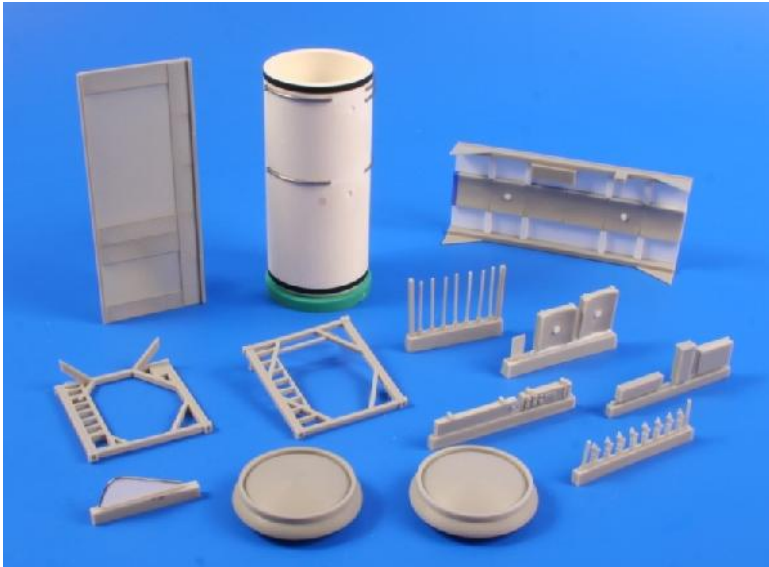

**Bar Code: 8595593121048**

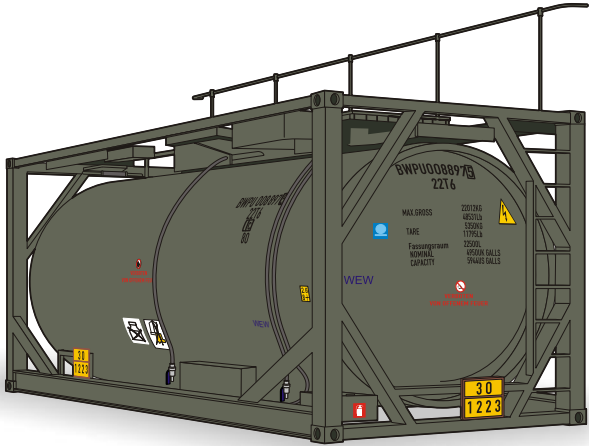
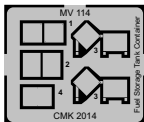

**ITEM**  
**Q72 203**

**Vampire T.11- Ejection seats MB Mk.3B for Airfix kit (2 pcs)**

**Scale**  
**1/72**

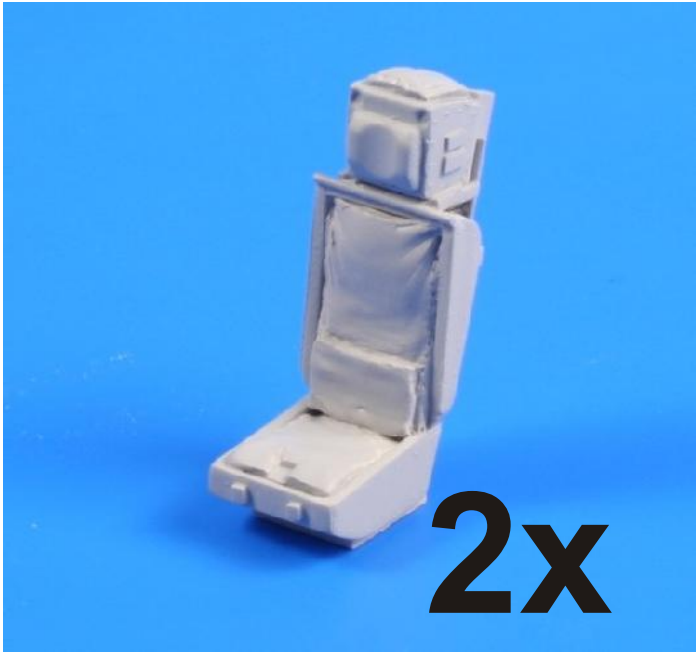

**2x**

Detailed set contains two all-new Martin-Baker Mk.3B seats. The seat belts are made from coloured photo-etch.

The Vampire T.11 was a trainer version of the British post-war jet fighter plane. The set contains also a colour photo-etch.

**GB / Post WWII**

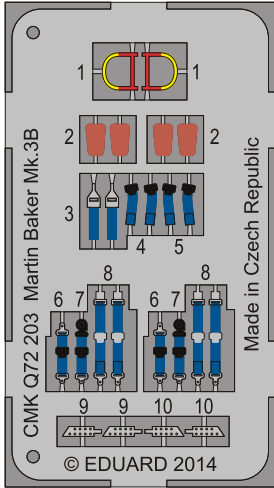

**Bar Code: 8595593121093**

ITEM  
Q72 204

**MG 131 - WW II German aircraft  
machinegun 13mm (8 pcs)**

Scale  
1/72

The set contains eight highly detailed 13mm MG131 aircraft machine guns that were used in many of Luftwaffe's machines during the Second World War, for example in Bf 109, Me 410, Fw 190, Ju 88, He 177.... The machine guns are made as a one-piece cast and have their barrel with realistically represented cooling perforation.

**Germany / WWII**

Bar Code:8595593121109

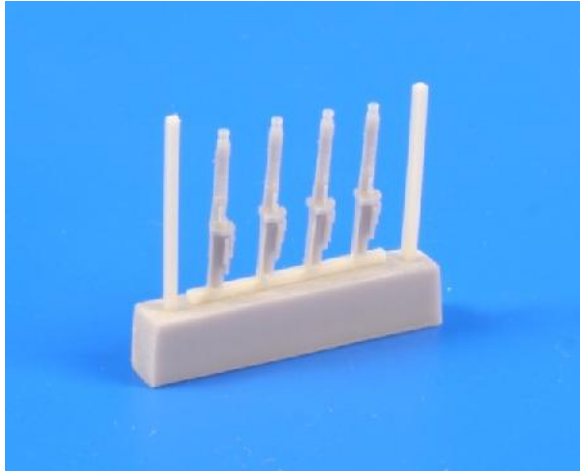
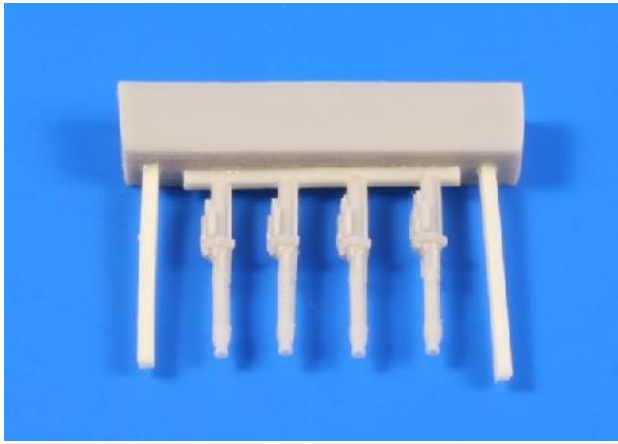

ITEM  
Q72 205

**Bf 109G-6 - Exhausts for Airfix kit**

Scale  
1/72

The set contains detailed cast resin exhausts for Airfix Bf 109 G-6 model. The exhausts were 3D CAD designed.

**German / WWII**

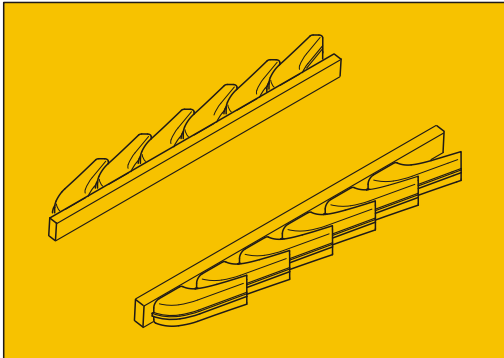

Bar Code: 8595593121116



ITEM  
Q72 206

### Lancaster Mk. I/II/III - Seats for Airfix/Hasegawa kit

Scale  
1/72

This detailed set contains three all-new air-crew seats for the plane's cockpit. The seat belts are made of colour photo-etch. The Avro Lancaster was the most commonly used four-engined bomber in the RAF service during WW2. The set contains also a coloured photo-etch.

GB / WWII

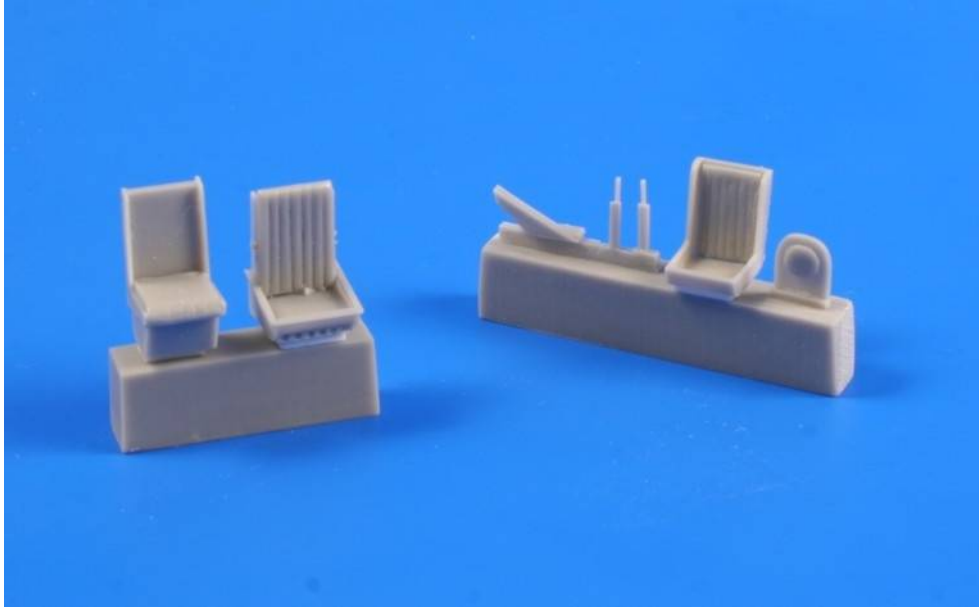
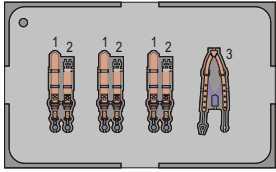

Bar Code:8595593121123

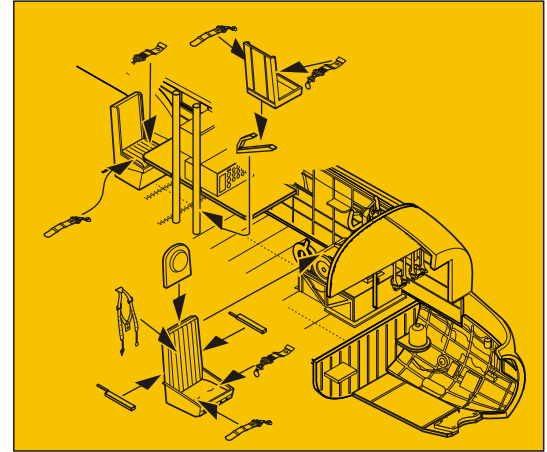

ITEM  
Q72 207

### Lancaster Mk. I/II/III - Instrument panel for Airfix / Hasegawa kit

Scale  
1/72

Detail set is containing new cast instrument panel with colour photo-etch. Rudder pedals are also in this set. The Avro Lancaster was the most commonly used four-engined bomber in the RAF service during WW2. The set contains also a coloured photo-etch.

GB / WWII

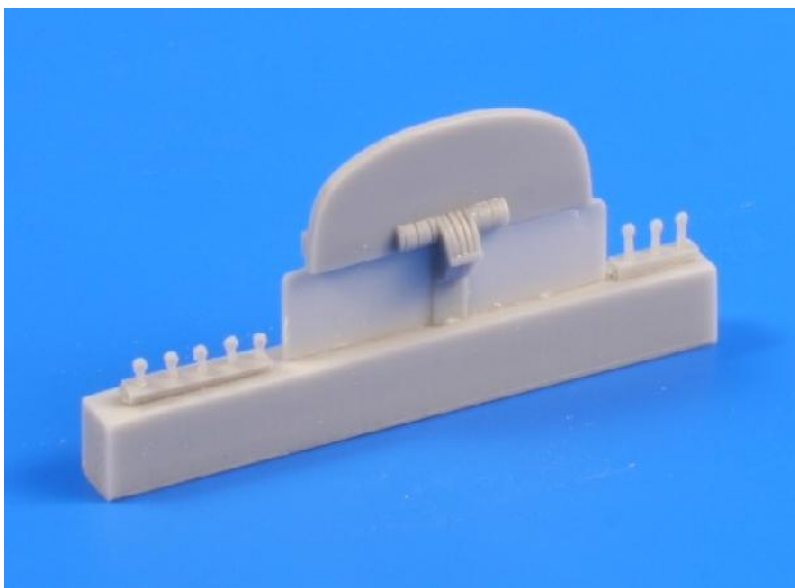
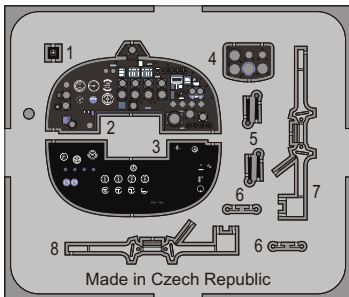

Bar Code:8595593121130

