

During the last September weekend, one of the biggest shows related to plastic modelling in the Czech Republic called E-day 2014 took place in Prague. We couldn't have missed such an important event. We managed to prepare some of our delayed news and put them up for sale on this event. They will also be regularly available during this week. There were also two models which had been initially intended for October that had their sneak-preview during the E-day. Quite a rare thing for us. So, these October new models were prepared for you:

SH72277 AH-1S Cobra "IDF against Terrorists" 1/72

Bar Code: 8594071084660

Israel obtained and subsequently tested the AH-1G Cobra attack helicopters. Due to the need of helicopters capable of destroying armoured vehicles or the enemy's fortified strongholds, Israel in cooperation with US counterpart converted these helicopters to the AH-1S version. AH-1S version was equipped with TOW missiles. Israeli helicopters still retained several features typical for the older AH-1G version helicopters. The sprues of this kit, six frames



in grey styrene contain highly detailed plastic parts with finely engraved panel lines, clear parts frame with canopy that is divided into five parts (which means you can built Cobra either with canopy closed or open), landing lights and highly detailed resin parts for the IDF version. Decals included offer markings for 4 brown (one of them with two slightly different markings) machines with two of them sporting Yellow ID "V" letters.

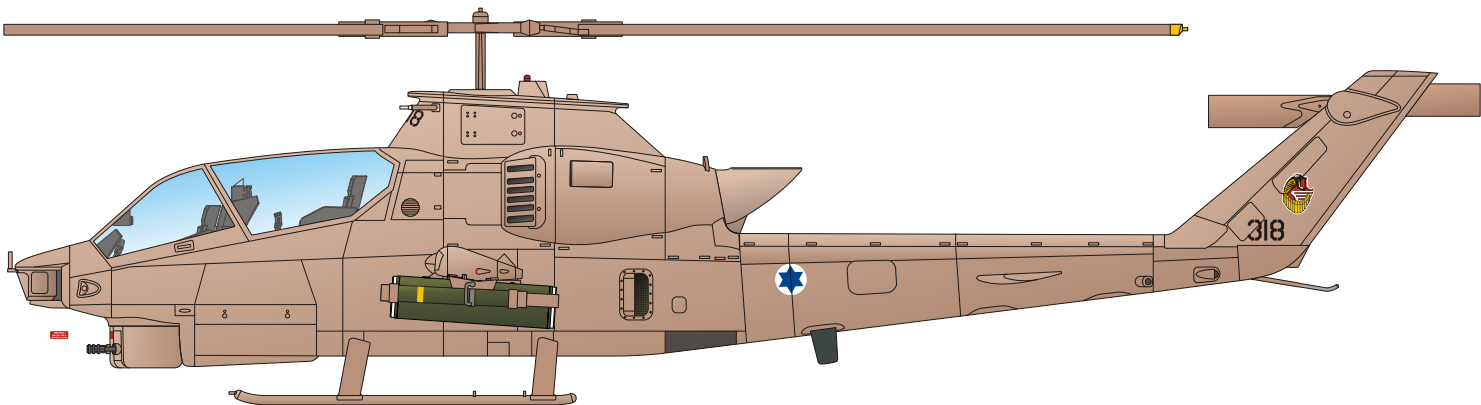
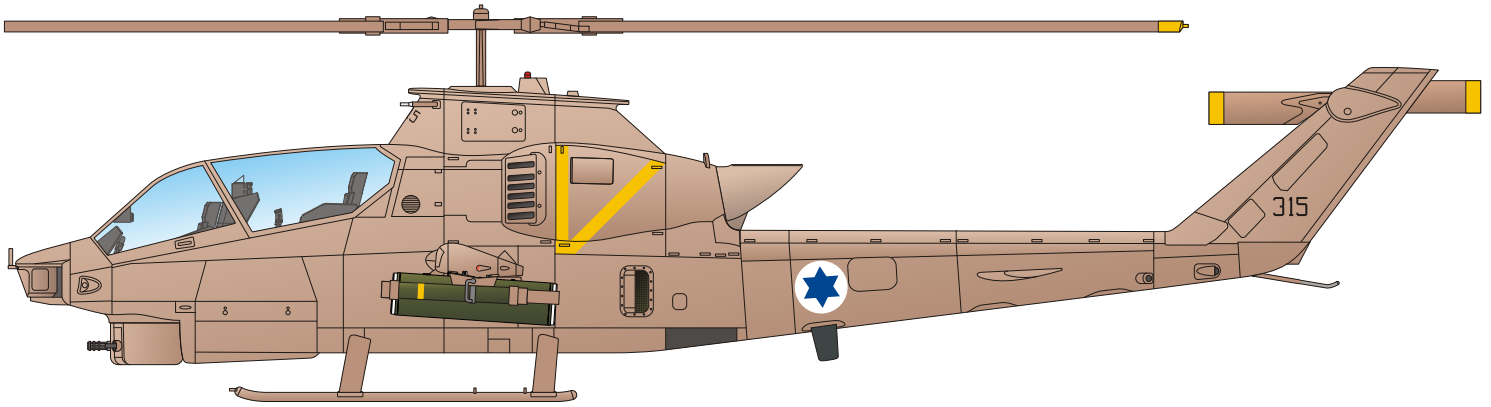
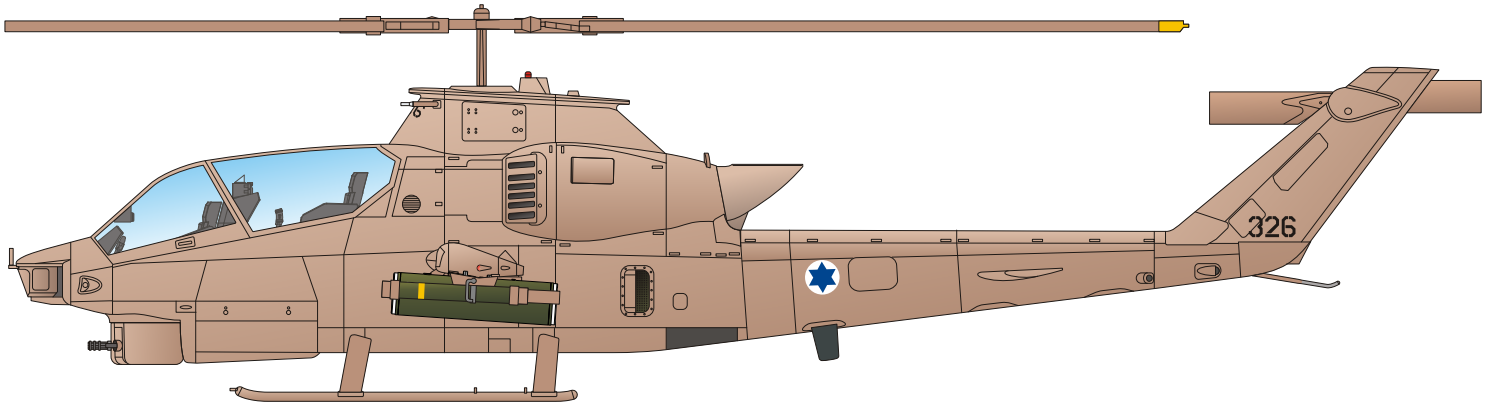
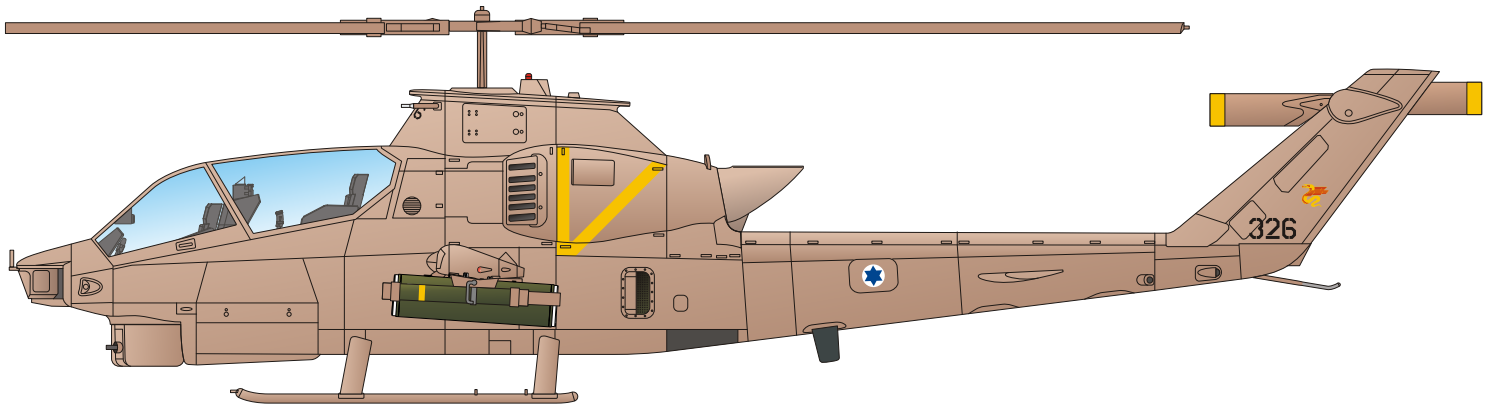

The training of the pilots and other personnel in the newly formed Luftwaffe took place in the aviation schools Flugzeugführerschule A/B with aircraft types that were divided into A1/2 and B1/2 categories. In 1935 the Luftwaffe called for a new all metal low wing monoplane type for the advanced training in the B1 category within the fighter training schools. The plane was to be developed and manufactured in AGO company. The final aspect of Ar 96B powered by As 410 engine was tested on the V-5 prototype. The production ran both at Arado Co so at AGO Co and was also subsequently started at Avia and Letov companies in the former Protectorate Bohemia and Moravia. After the war these companies continued to produce the Ar 96B designated as Avia C-2 for the re-established Czechoslovak Air Force. Ar 96Bs were produced in additional subversions denoted by a dash and number. The main subversions were unarmed B-1 and B-7 for the pilot training and machine guns equipped B-2, B-3 and B-8 for the gunner training. The Arados were assigned to all types of aviation schools; both to the advanced fighter schools so to the ground attack and replacement fighter (training) schools and were used until the end of the war. The Arados were even exported. With the increase of Ar 96B numbers Luftwaffe sold Arado Ar 96A with less powerful engines to Hungary and the Slovak State. Later on, Hungary also purchased Ar 96Bs. The trainer-ground attack version of Ar 96B according to the Ar 96B V-9 prototype was produced in small number for Bulgaria. These aircraft featured modified rear cockpit with flexible mounted machine gun. Although the end of the war meant the end of Arado Ar 96 history, it was also beginning of Avia C-2 history. After the war the Czechoslovak Air Force started wide training programme for new pilots. The later was even widened after the communists' takeover. For these purposes were used captured German machines and as the production was renewed in Avia and Letov in August 1945, also the new machines were used. These aircraft were in Czechoslovakia designated Avia C-2. Similarly to Germany, Avias were produced with or without armament. Some of these machines was equipped with Letov propeller with smooth skin spinner. Avias nicknamed "Tin Mary" served in Flying School, Air Force Academy and even with combat units or Police Air Force (SNB AF) until its decommissioning in 1956. Even the Czechoslovak aircraft were exported, mainly to the Soviet Block countries Hungary and Bulgaria. The seized, originally German aircraft were used by training units in France, while Great Britain and the USA tested only very few of the captured machines.

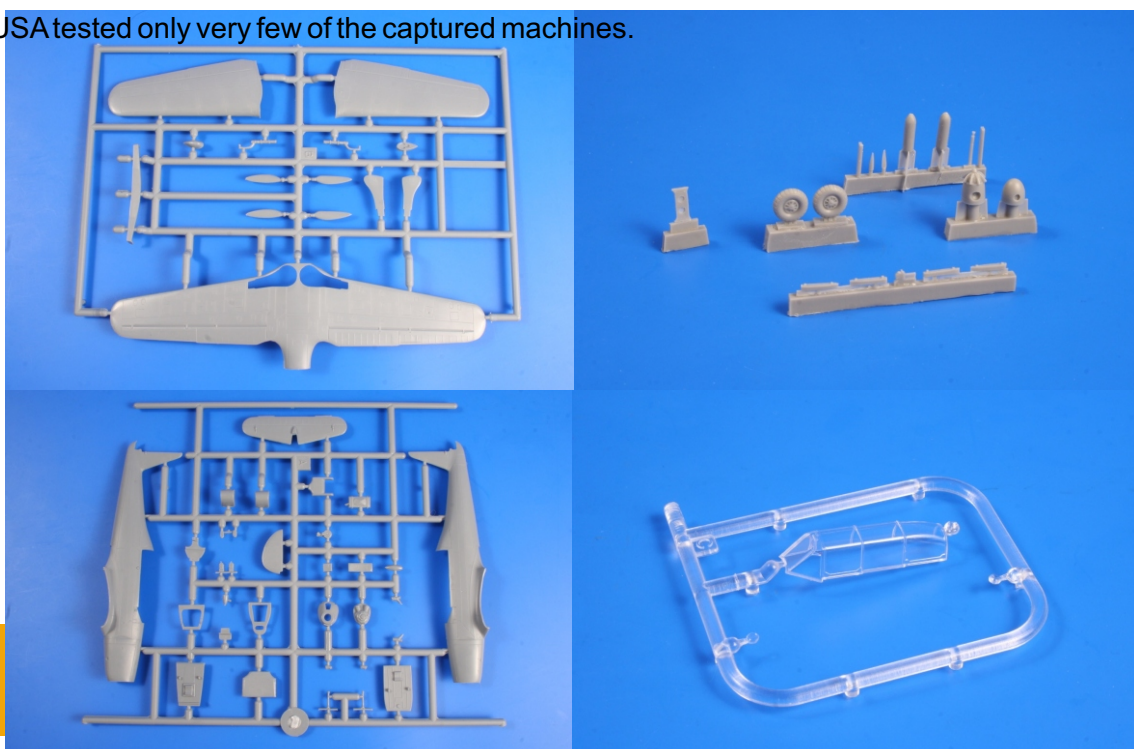

The Arado Ar 96 model has been prepared in three different boxings:

SH72310 Avia C.2 1/72

bar code: 8594071084615

The post-war service of the Arados, known as the Avia C.2 in Czechoslovakia, is charted in the first of them. It offers two frames of plastic parts, crystal clear injected canopy and landing lights lenses, detailed resin parts and a set of photo-etched parts. There are three machines offered on the decal sheet, all of them in the natural metal finish, two of them with yellow stripes. One machine is original German Arado Ar 96B, the two others were made after the war.

1 special
72 HOBBY



Avia C.2

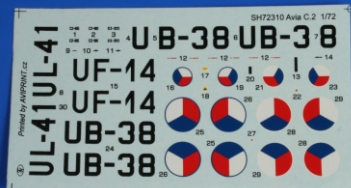
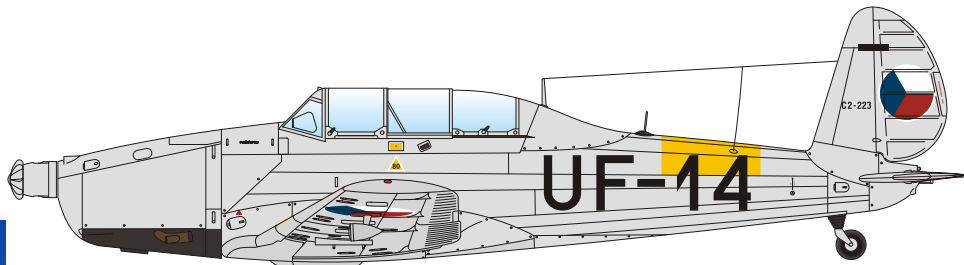
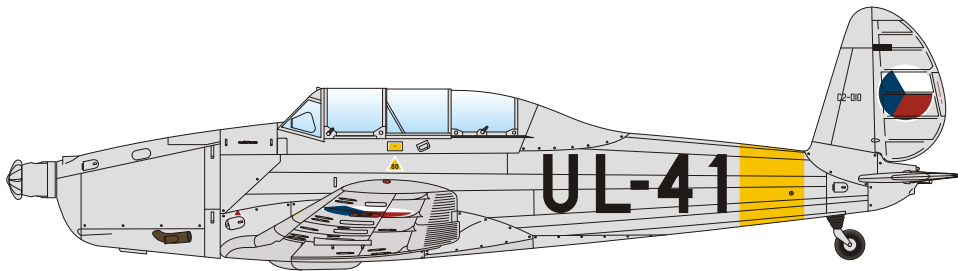
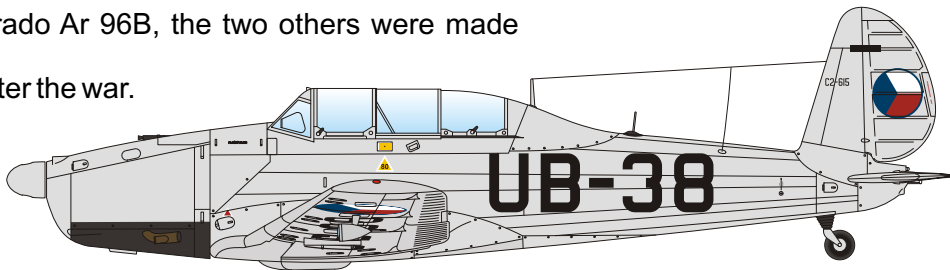

The unarmed Arado Ar 96B-1 served in the Luftwaffe for advanced pilot training. Parts of this model are identical with the previous model, there is difference only in the box and the decals, of course. The decal sheet offers three different machines from various flying schools. All of them bear markings of the Luftwaffe, the school units' badges and are interesting also for some repairs of their camouflage. Two machines wear three-colour camouflage scheme, while the last machine is only in RLM 02 and is also having its u/c covers removed.

1^{special}
72 HOBBY

Arado
Ar 96B-1

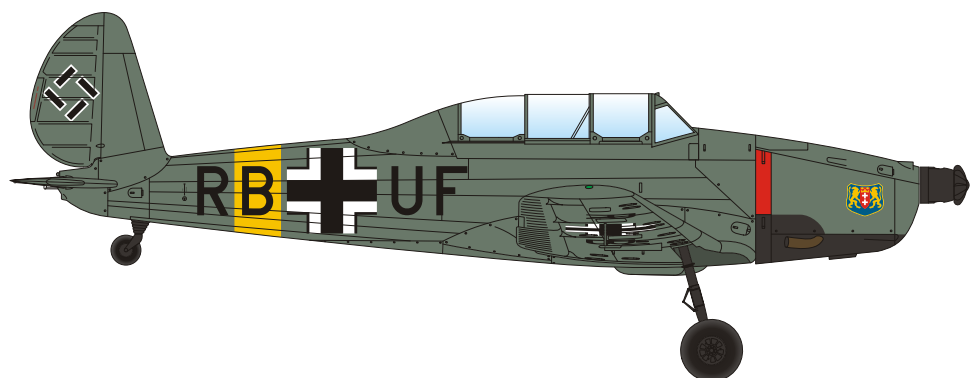
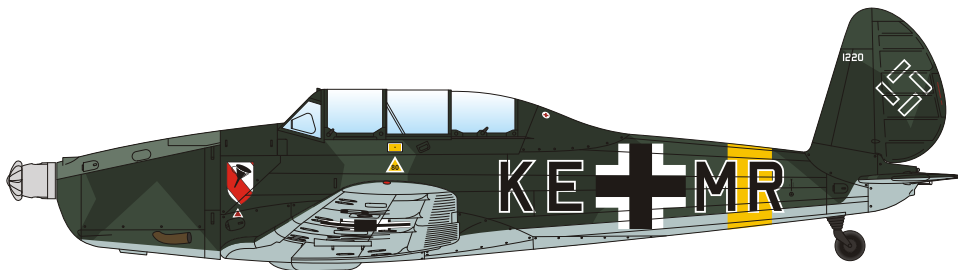
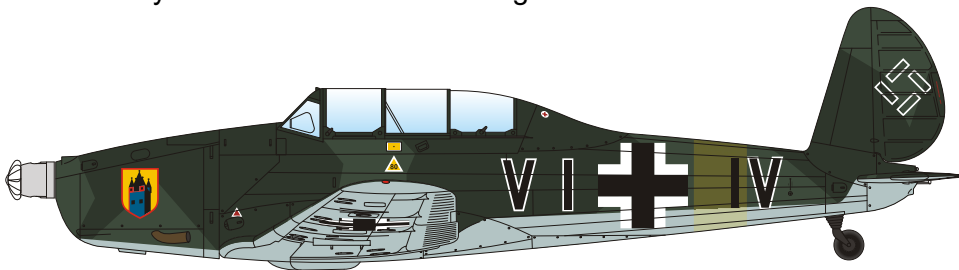

The Arado Ar 96B-3, which was armed version of this plane, served for gunnery training with operational training units. The identical parts of this model are accompanied by the decal sheet with markings for three machines in RLM 02 grey. The first of them is VH+OZ / yellow 3, WNr.4326, which served with night training unit I./NJS 1 in Schleissheim, Germany. The other two machines flew in occupied France, Arado Ar 96B-3, black 4, belonged to 1./JG 107. This machine is



interesting for some of its fuselage panels behind the engine being replaced and the wing root panels painted with fresh and darker colour. The 3/JG101 unit was based in Tarbes Lourdes in southern France and used Arado Ar 96B-3, DQ+YD with markings of its previous user, the JFS 2 Flying School.

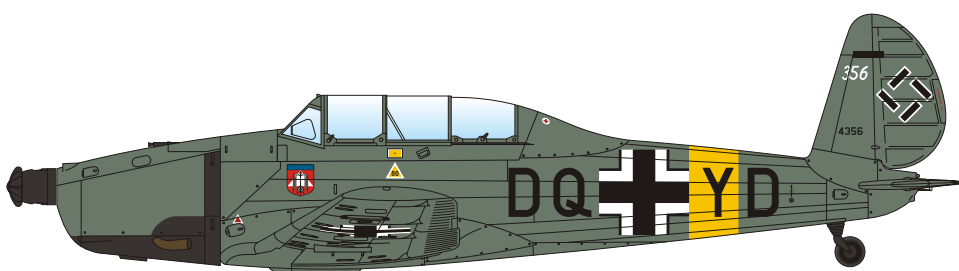
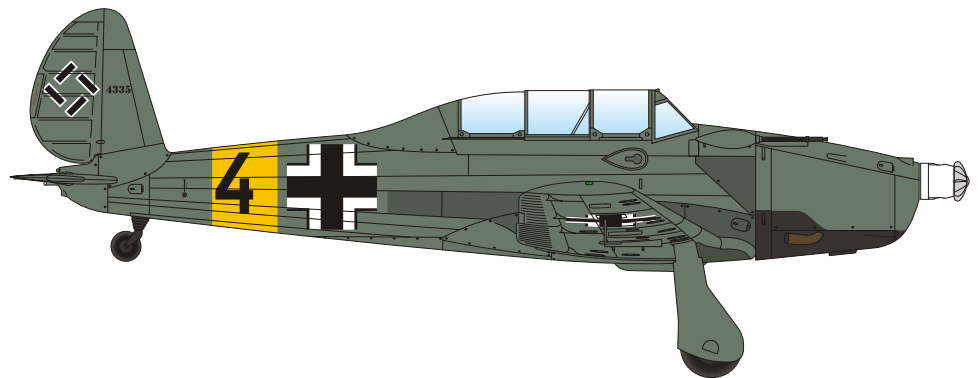
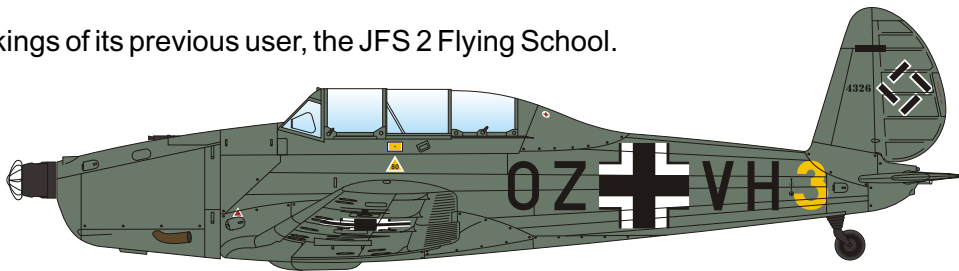

Two of our long sold out but still ordered models have been put into production again.

Mainly the nordic retailers are keeping ordering and pressing for reedition of the ASJA/SAAB B-5 model, so we would like to comply with their wishes and this model is available again in a 500pcs limited edition.

72514 ASJA/SAAB B-5 "Swedish Dive Bomber" 1/72

Bar Code: 8595019310575

Before WW2 Sweden bought a licence in the USA to produce the Douglas DB-8 (A-17) bomber. The Swedish version was significantly improved. It differed by the Bristol Pegasus engine, undercarriage, cockpit canopy and other details. The machines served throughout

the war, but as Sweden was a neutral country, they did not take part in the fightings.

The model contains two sprues with plastic parts that are accompanied by a large set of resin parts, including the detailed engine. The model also contains injected gunner's canopy

vacu canopy for the pilot cockpit and coloured photo-etches. The kit offers all three options for the plane's undercarriage.

The machine flew either with wheeled undercarriage with its aerodynamical covers or without them, or with skis. The decals offers three machines. It is possible to build the model with its white winter camouflage, or in standard camouflage scheme or in natural metal finish.

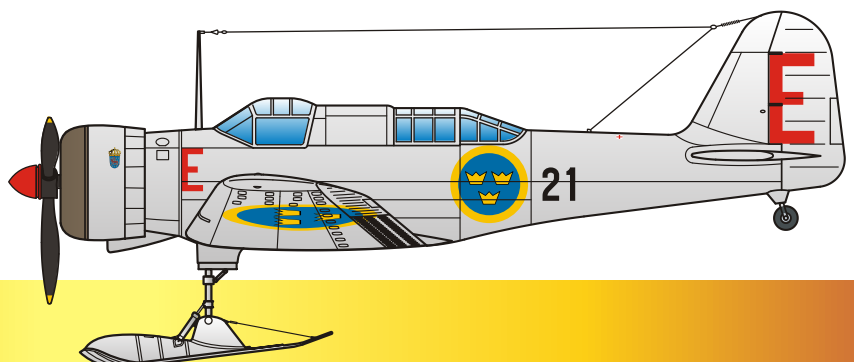
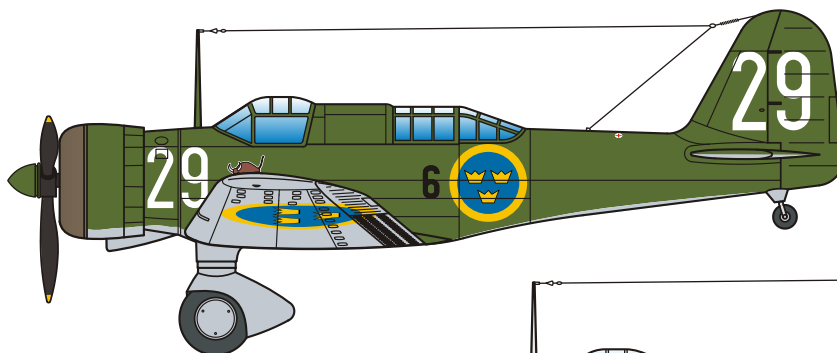
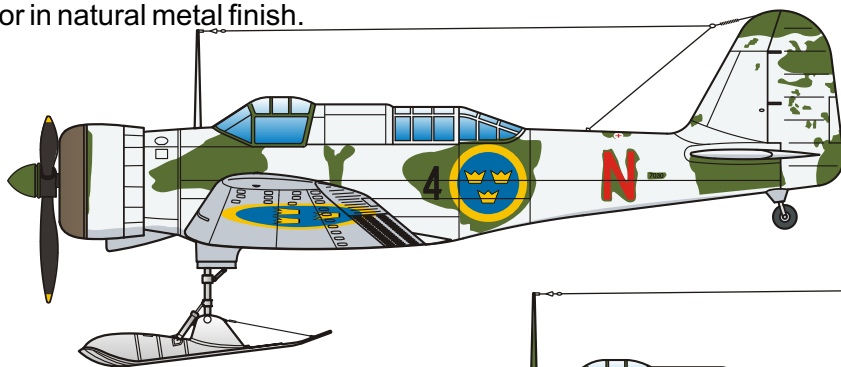

Likewise, also the Breda Ba.88B in 1/72 is produced again. There are colour photo etches available now for this model, these are: **K72002 Ba.88B** and **K72005 Italian seatbelts**.

72538 Breda Ba 88B Lince 1/72

Bar Code: 8594071082000

During World War 2 Italy used only two twin-engined bombers. In the overflow of the tri-engined bombers only Fiat BR.20 Cicogna and Breda Ba.88 Lince succeeded. Just before the outbreak of WW 2 Breda Ba.88 achieved several speed records. The Italian High Command bid fair too much on these sleek and powerful machines. The combat assignment revealed unreliability of the engines and other systems. Even though the Ba.88s served until Italian armistice and even then several machines flew in Luftwaffe colors.



The highly detailed kit contains three sprues with plastic parts and injected canopy. Decals included offer three machines in four-colour Italian continent camouflage of the early period of WW 2. All three machines feature Piaggio P.XI RC.40 engines with plain cowlings.

Doporučujeme k modelu 72538

We recommend for kit no.72538:

K72002

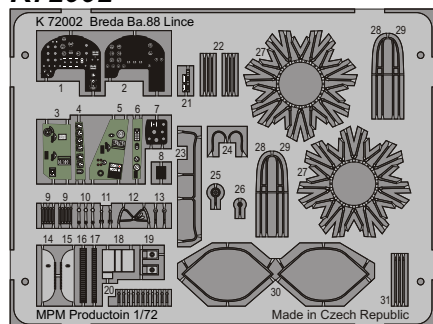

K72005

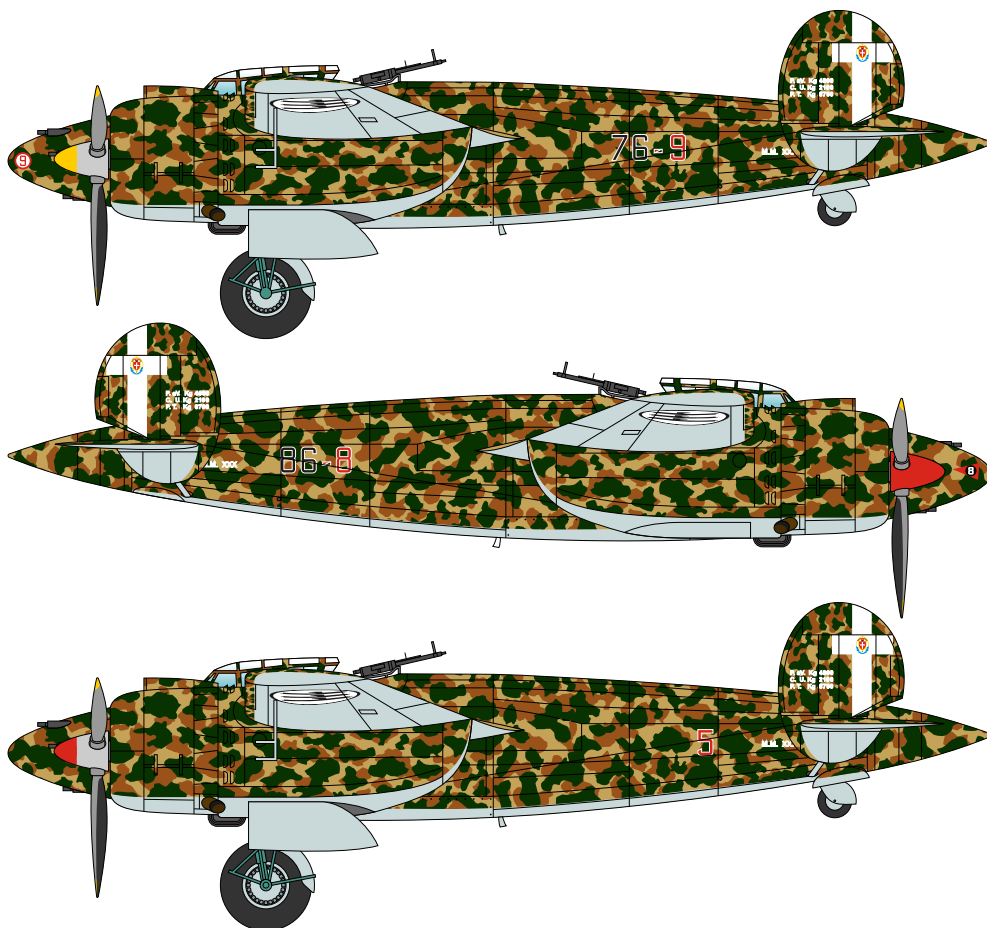
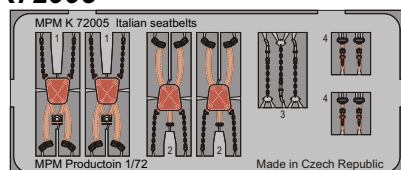

Forthcoming new releases:

SH48135
AF-2S Guardian "Submarine Killer" 1/48



SH48158
AF-2W Guardian "Submarine Hunter" 1/48



SH72299
N-3PB "Little Norway" 1/72



SH72250
N-3PB "No. 330 (Norwegian) Squadron RAF" 1/72



SH32061
Fiat G.50-II "Regia Aeronautica" 1/32



SH72313
Caproni Ca.311 "Foreign Service" 1/72





RESIN KITS and SETS 10/2014

MPM Production Ltd., Mezilesí 718, 193 00, Praha 9, Czech Republic
tel.: +420 281 923 909 fax: +420 281 923 910 e-mail: cmk@mpm.cz
official website and e-shop: www.cmkkits.com

ITEM
F35 261

WW II German Hetzer Crewmember

Scale
1/35

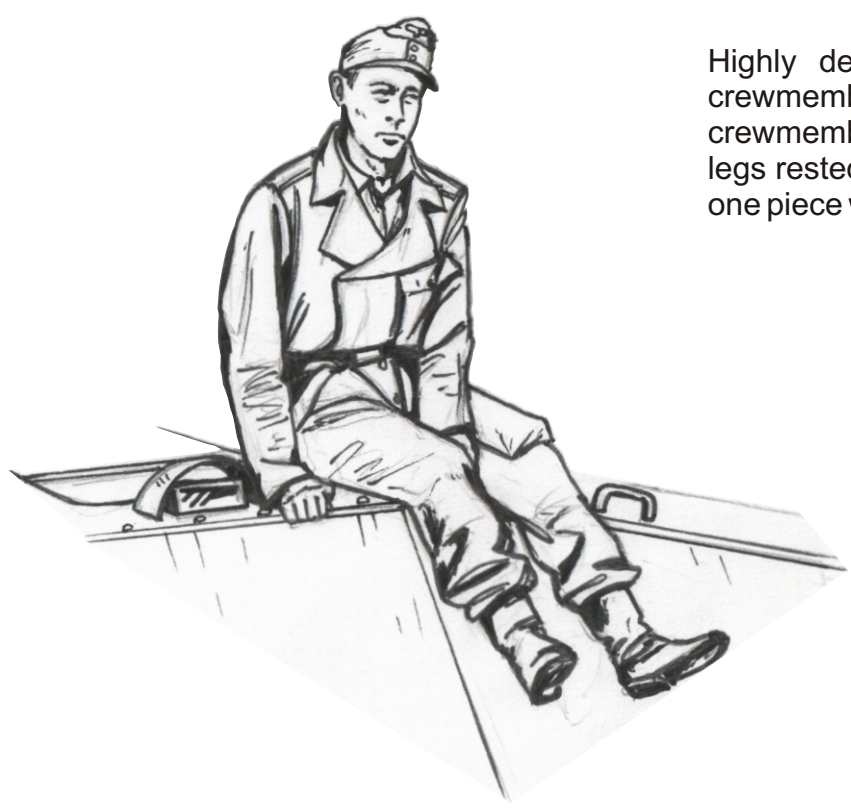

Highly detailed resin cast figure of German tank crewmember was designed for Hetzer tank hunter. The crewmember sits on the Hetzer's armoured roof with his legs rested on the sloping armour. The figure is cast in one piece with only separated head and right arm.

Bar Code: 8595593121710



ITEM
5090

Scale
1/32

F-104G/S Interior set for German and Danish G and Italian S version (European version with MB.GQ-7A seat) for Italeri kit

Highly detailed set contains cockpit for F-104G used by German Air Force and Navy, Danish Air Force and Italian Air Force modernized F-104S. F-104s used by the above mentioned states were equipped with Martin Baker GQ-7A ejection seats (Other European F-104s were equipped with Lockheed C-2 ejection seats). Set contains cockpit tube, ejection seat, instrument panel, sidewalls, bulkheads and other small parts.

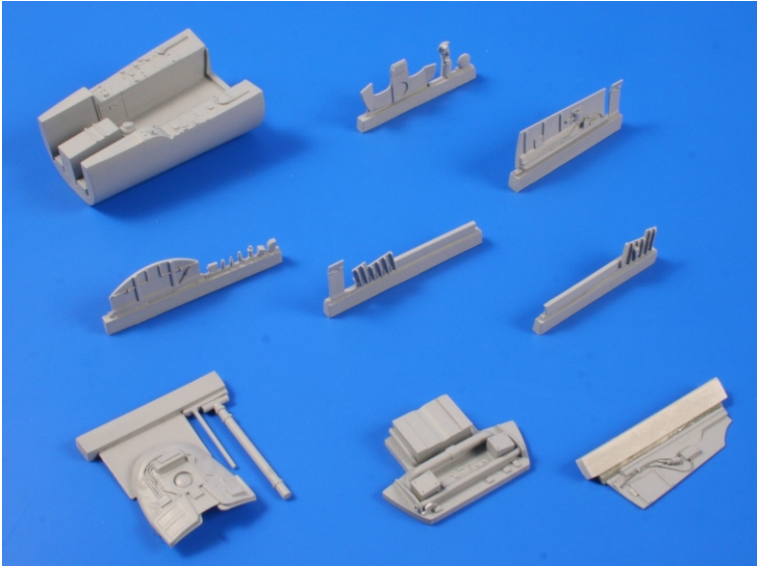
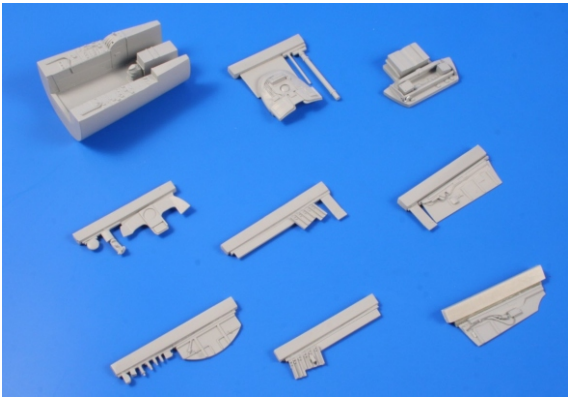

Code: 8595593121727

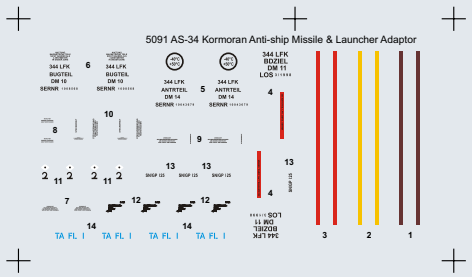
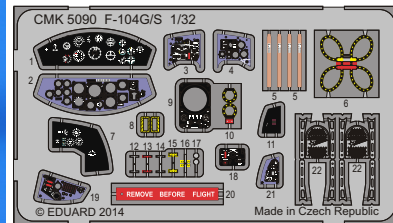

ITEM
5091

Scale
1/32

AS-34 Kormoran 2 Anti-ship Missile & Launcher Adaptor (2 pcs)

Set contains 2 highly detailed AS-34 Kormoran 2 Anti-ship missiles that are carried by German and Italian Tornado aircraft. The missiles are cast in one piece with only separate fins and rear section with engine. The set also contains launcher adaptors, decal sheet with stencils, 20 color photo-etched Remove Before Flight tags.

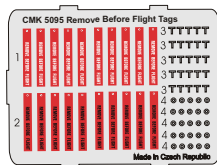
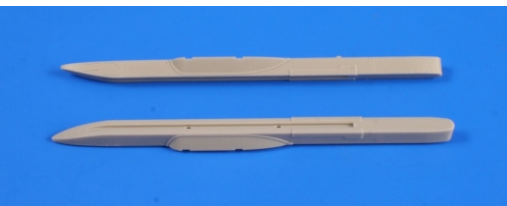

Bar Code:8595593121734

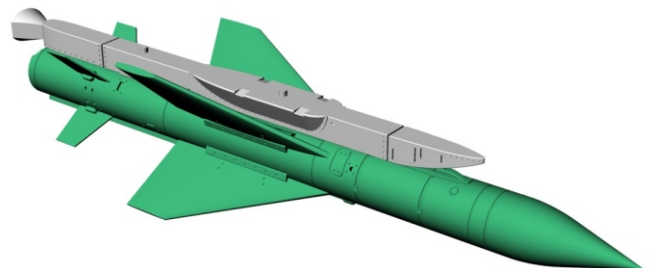

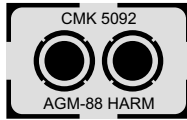
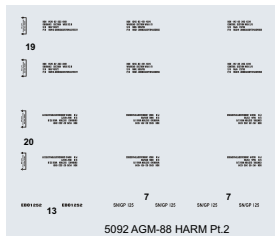

**ITEM
5092**

**AGM-88 HARM Air-to-Surface Missile
+ NATO / US LAU-118 Launcher Adaptors
(2 pcs)**

**Scale
1/32**

Set contains 2 highly detailed anti-radiation air-to-surface missiles. The missiles are cast in one piece with only separate mid-body fins. The set also contains NATO launcher adaptors, LAU-118 launcher adaptors for US aircraft, decal sheet with stencils, 20 color photo-etched Remove Before Flight tags and plain photo-etched fret with rocket engine nozzles.

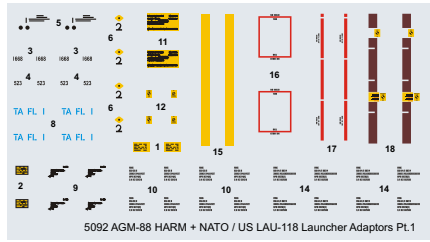

Bar Code: 8595593121741

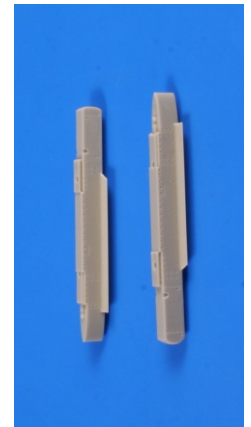
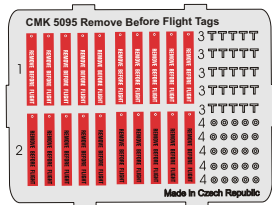
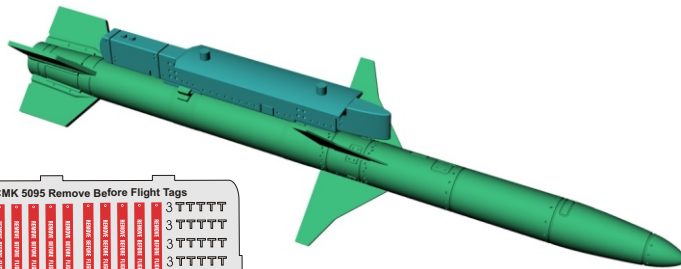

**ITEM
5097**

F-104G/S – Engine set for Italeri kit

**Scale
1/32**

Highly detailed set contains General Electric J79 engine. Solid resin cast engine including the fuselage bulkheads can be easily installed into the lower fuselage portion. Other parts comprise particular cover and small parts. The set is intended for one of the best known and widely used US jet aircraft that was flew in USA, Europe, Japan and Canada.

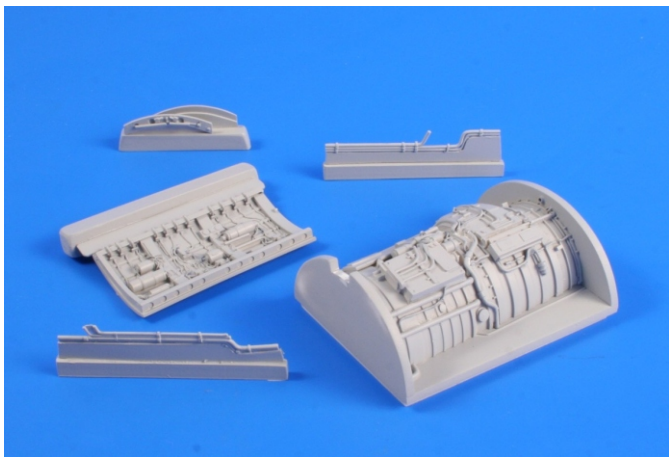

Bar Code:8595593121758

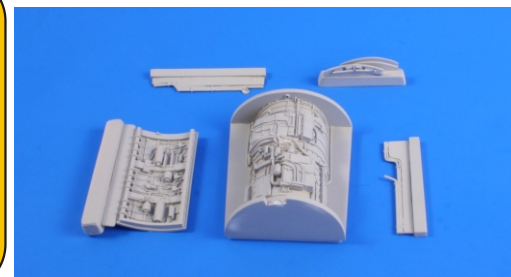
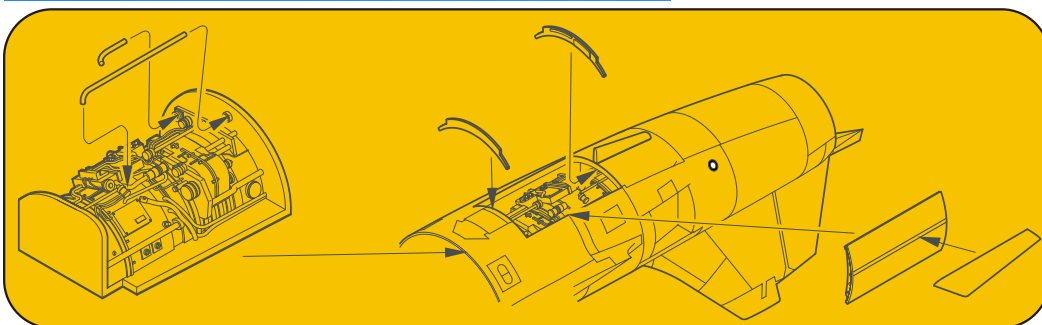

ITEM
5098

**F-104G/S – NASSAR Radar set
for Italeri kit**

Scale
1/32

Highly detailed set contains nose mounted NASSAR radar (North American Search And Ranging Radar). The radar is cast from highly detailed parts including the fuselage bulkhead; the radome is cast separately. The set is intended for one of the best known and widely used US jet aircraft that was flew in USA, Europe, Japan and Canada.

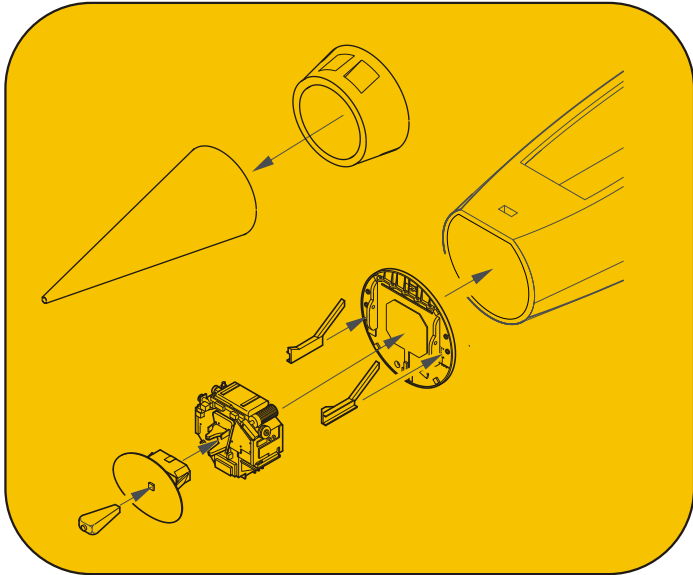

Bar Code:8595593121765

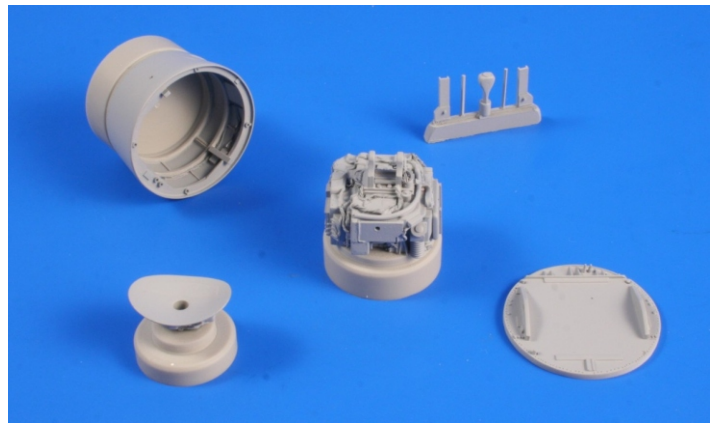

ITEM
5099

F-104G/S – Undercarriage set for Italeri kit

Scale
1/32

The set contains completely new main undercarriage bay including fuselage bulkheads, wiring and piping. The small undercarriage covers and included too. Use kit parts big undercarriage doors that were deployed only during takeoff and landing. The set is intended for one of the best known and widely used US jet aircraft that was flew in USA, Europe, Japan and Canada.

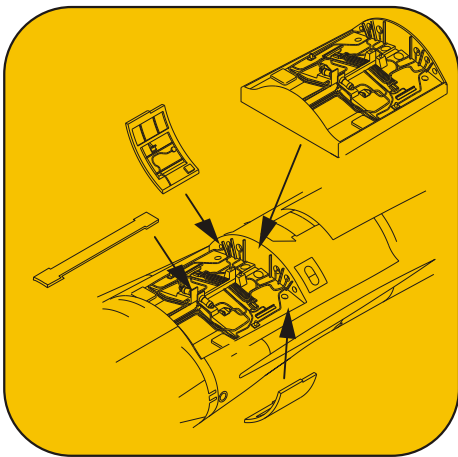

Bar Code:8595593121772

ITEM
4312

Scale
1/48

AS-34 Kormoran 2 Anti-ship Missile & Launcher Adaptor (2 pcs)

Set contains 2 highly detailed AS-34 Kormoran 2 Anti-ship missiles that are carried by German and Italian Tornado aircraft. The missiles are cast in one piece with only separate fins. The set also contains launcher adaptors, decal sheet with stencils, 20 color photo-etched Remove Before Flight tags.

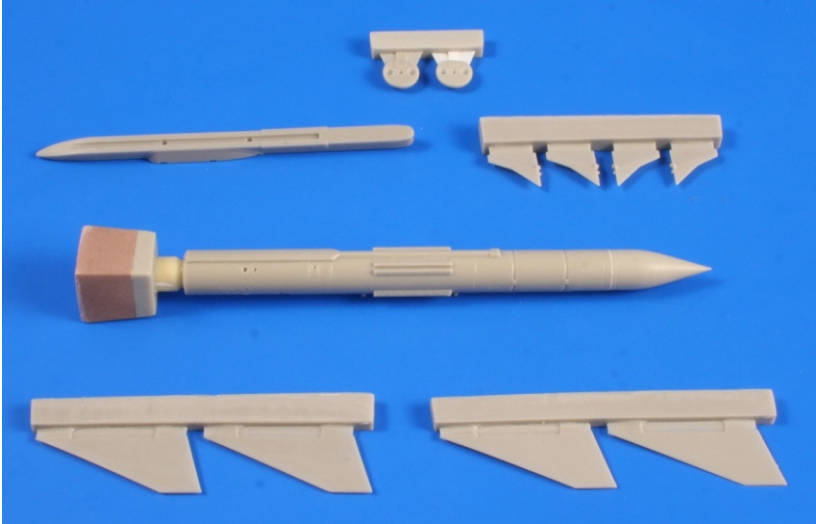
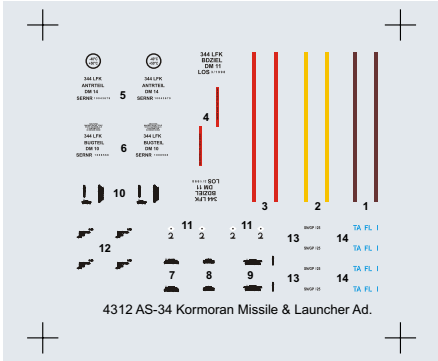

Bar Code:8595593121789

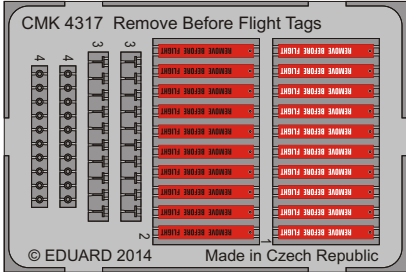

ITEM
4314

Scale
1/48

AGM-88 HARM Air-to-Surface Missile + NATO / US LAU-118 Launcher Adaptors (2 pcs)

Set contains 2 highly detailed anti-radiation air-to-surface missiles. The missiles are cast in one piece with only separate mid-body fins. The set also contains NATO launcher adaptors, LAU-118 launcher adaptors for Us aircraft, decal sheet with stencils, 20 color photo-etched Remove Before Flight tags and plain photo-etched fret with small parts.

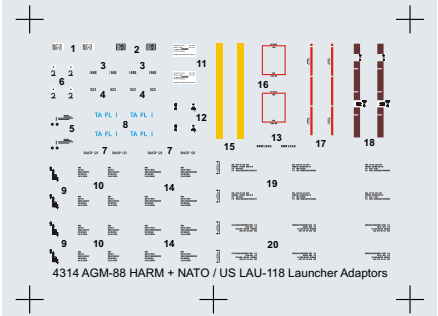

Bar Code:8595593121796

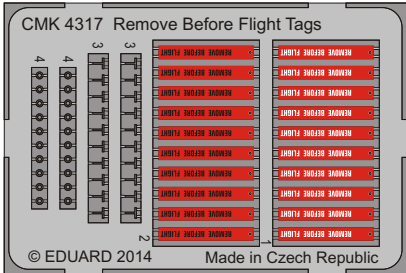

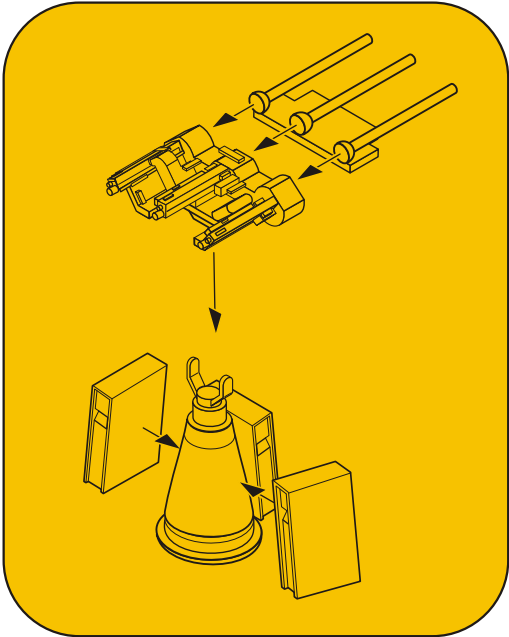

Full resin kit of one of the most widespread German small calibre Anti Aircraft device from the end of World War II. The swivel mount with three 20 mm MG 151/20 cannons was highly efficient not only against low flying aircraft but also against light armoured enemy vehicles. The “Drilling” was at the end of the World War II mounted almost on all German wheeled vehicle (including trailers) as the emergency anti aircraft defence system (well known is the installation on Sd. Kfz 251 and even on the Opel Blitz , Mercedes 3000, etc.). The “Drilling” were often used as train defence and fixed defence system for airports, bridges, important junctions, etc.

Bar Code:8595593121802